



CONNECTION GUIDE	1
TABLE OF CONTENTS	2

SECTION 1 HIGH PRESSURE UNITS

PRESSURE WASHERS	
Briggs & Stratton Units	7
Robin Units	8

HONDA UNITS	
5 HP Direct Drive	10
6 HP Direct Drive	11
5.5 HP Direct Drive	12
6.5 HP Direct Drive	13
9 HP Direct Drive	14
11 HP Direct Drive	15
13 HP Direct Drive	16

Replacement Engines & Base Plates

HONDA STAINLESS STEEL UNITS	
5.5 HP Direct Drive	18
6.5 HP Direct Drive	19
9 HP Direct Drive	20
9 HP Direct Drive Large	21
11 HP Direct Drive Large	22
13 HP Direct Drive Large	23
13 HP Belt Drive	24
Internet Profile	25
COOLDRIVE Features	26
13 HP COOLDRIVE	27
20-24 HP Belt Drive	28
20-24 HP Geardrive	29

BALDOR ELECTRIC	
1.5 HP Baldor	30
2 HP Baldor	31
5-10 HP Baldor	32
2 HP Pack-A-Round	33

GENERATORS	
Feature Spread	34
5 HP	36
5.5-13 HP	37

WATER PUMPS	
General Purpose Water Pumps	38
Trash and High Pressure Pumps	39
Hose Kits and Camlocks	40

HYDROSTATIC TESTERS	
5.5 HP AR	41
5.5 HP Comet	42

DRAIN CLEANERS	
1.5 - 24 HP	43

HOT WATER UNITS	
Hot Towers	44

SECTION 2 SPECIALTY CLEANING UNITS

WATER BROOMS	
Large Water Broom	48
Small Water Broom	48
Ball Valve Kit	48

FLAT SURFACE CLEANERS	
POLYPROPYLENE	
16" Whirl-A-Way	49
18" Whirl-A-Way	50
20" Whirl-A-Way	51

STAINLESS STEEL	
20" Whirl-A-Way	52
24" Whirl-A-Way	53

TELESCOPING WANDS	
Fiberglass	54
Aluminum	56
Paint Poles and Accessories	57

SECTION 3 MATERIAL HANDLING GOODS

Dolleys and Trolleys	60
Hand Carts and Hydraulics	61
Utility and Tool Carts	62
Jacks	63
Trailer Jacks	64

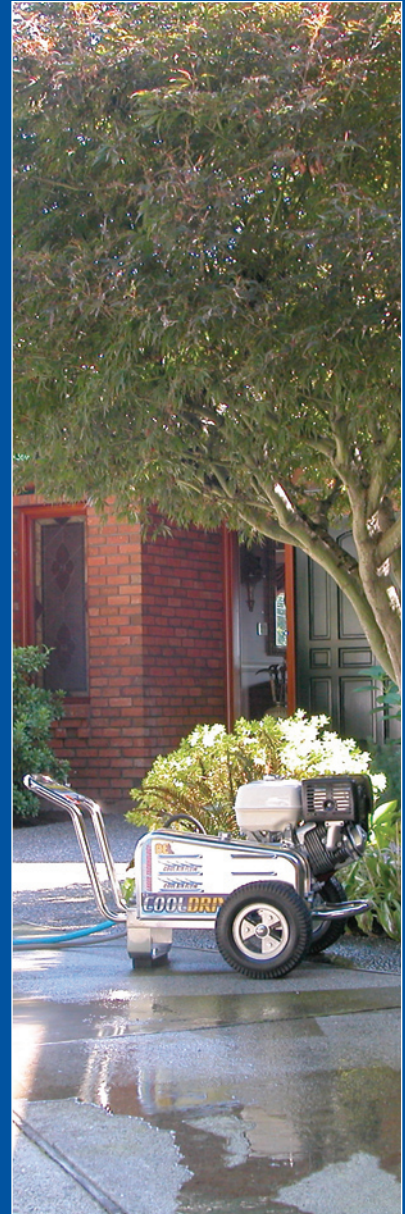



SECTION 4
PRESSURE WASHER PUMPS 66

CAT PUMPS

2DX, 3DX	68
2SF	68
66DX	68
5CP	68

COMET PUMPS

AXD	69
GXD	69
LWD	69
ZWD	70
FW/HWS	70
TW	70

GENERAL PUMPS

TP	71
TZ/TX	71
T	71
TS	71

PUMP KITS

Cat Pump, Seal & Valve Kits	72
General Pump, Kits	72
Comet Pump, Seal & Valve Kits	73
Replacement Oil Caps	73

SECTION 5
BASIC ACCESSORIES 74

Spray Guns	76
Wands and Lances	78
Wands and Handles	79
Low Pressure Spray Kits	80
Packaged Parts Profile	80
Spray Nozzles, Quick Connect	82
Spray Nozzles, Meg	83
Nozzles and Holders	84
Rotary Nozzles	85
High Pressure Hoses	86
Low Pressure Hoses	87

SECTION 6
VALVES AND FITTINGS 88

Unloaders	90
Ball Valves	92
Valves	94
Valves and Chemical Injectors	95
Orings	96
Sure-Lock Couplers	97
Couplers and Plugs	98
Fittings	99
Garden Hose and Nozzle Fittings	100
Nozzle Fittings and Screens	101

SECTION 7
KITS & CUSTOM ACCESSORIES 102

Hose Reels	104
Engine Parts	105
Sandblast Kits	106
Brushes and Kits	107
Power Accessories	108
Fluid Accessories	109
Pressure Gauges	110
Chemical Kits and Parts	111
Filters and Strainers	112
Miscellaneous Water Accessories	113
Electrical Accessories	114
Replacement Blocks and Feet	115
Tires and Wheels	116
Tiller Tines and Blades	117

WARRANTY POLICIES	118
COMPANY PROFILE	119





SECTION 1

HIGH PRESSURE UNITS

PRESSURE WASHERS

BRIGGS & STRATTON UNITS	7
ROBIN UNITS	8

HONDA UNITS

5 HP Direct Drive	10
6 HP Direct Drive	11
5.5 HP Direct Drive	12
6.5 HP Direct Drive	13
9 HP Direct Drive	14
11 HP Direct Drive	15
13 HP Direct Drive	16

Replacement Engines & Base Plates	17
--	----

HONDA STAINLESS STEEL UNITS

5.5 HP Direct Drive	18
6.5 HP Direct Drive	19
9 HP Direct Drive	20
9 HP Direct Drive Large	21
11 HP Direct Drive Large	22
13 HP Direct Drive Large	23
13 HP Belt Drive	24

Internet Profile	25
-------------------------	----

COOLDRIVE Features	26
---------------------------	----

13 HP COOLDRIVE	27
20-24 HP Belt Drive	28
20-24 HP Geardrive	29

BALDOR ELECTRIC

1.5 HP Baldor	30
2 HP Baldor	31
5-10 HP Baldor	32
2 HP Pack-A-Round	33

GENERATORS

Feature Spread	34
5 HP	36
5.5-13 HP	37

WATER PUMPS

General Purpose Water Pumps	38
Trash and High Pressure Pumps	39
Hose Kits and Camlocks	40

HYDROSTATIC TESTERS

5.5 HP AR	41
5.5 HP Comet	42

DRAIN CLEANERS

1.5 - 24 HP	43
-------------	----

HOT WATER UNITS

Hot Towers	44
------------	----

BE 



PACKAGING: Boxed





4.75HP

Comet VRX2022G
85.149.048B





Model#	BEVB-2004BWCOMX
Engine	4.75 HP Briggs & Stratton "Intek"
Pump	Comet VRX2022G Pump
Pressure	2,300 PSI
Flow	2 GPM
Weight	95 lbs
Features	
• 4,600 Cleaning Units	5 36" Insulated Lance
1 Composite Tires	6 Adjustable Vari-Nozzle
2 Chemical Injector	• Comet Pump
3 25' Steel Braid Rubber Hose	• Vertical Direct Drive
4 2,750 PSI Spray Gun	

6.5HP

Comet AXD2527G
85.149.026B



Model#	PE-2765BWCOMX
Engine	6.5 HP Briggs & Stratton "Intek"
Pump	Comet AXD2527G Pump
Pressure	2,700 PSI
Flow	2.5 GPM
Weight	95 lbs
Features	
• 6,750 Cleaning Units	3 25' Steel Braid Rubber Hose
• Adjustable Unloader	4 5,000 PSI Spray Gun
1 Thermal Relief Valve	5 36" Insulated Lance
• 10" Tubed Pneumatic Tires	6 4 Quick-Connect Spray Tips
2 Chemical Injector	• Direct Drive





13HP

Comet ZWD4040G
85.149.022B



Model#	PE-4013BWPCOMZ
Engine	13 HP Briggs & Stratton "Vanguard"
Pump	Comet ZWD4040 Pump
Pressure	4,000 PSI
Flow	4 GPM
Weight	175 lbs
Features	
• 16,000 Cleaning Units	2 Chemical Injector
• EZstart Adjustable Unloader	3 50' Steel Braid Rubber Hose
1 Thermal Relief Valve	4 5,000 PSI Spray Gun
• Safety Relief Valve	5 36" Insulated Lance
• 13" Tubed Pneumatic Tires	6 4 Quick-Connect Spray Tips





BLACK POWDER COATED FRAMES

PACKAGING: Boxed

	<h2>7HP</h2>		Model# PE-2570RWCOM PE-2570RWGEN
			Engine 7HP Robin 7HP Robin
Comet LWD-K3025G 85.149.015B			Pump Comet General
			Pressure 2,500 PSI 2,500 PSI
General TP-2530G 85.139.020B			Flow 3 GPM 3 GPM
			Weight 80 lbs 80 lbs
			Features
			<ul style="list-style-type: none"> • 7,500 Cleaning Units 3 25' Steel Braid Rubber Hose • Adjustable Unloader 4 5,000 PSI Spray Gun
			<ul style="list-style-type: none"> 1 Thermal Relief Valve 5 36" Insulated Lance • 10" Tubed Pneumatic Tires 6 4 Quick-Connect Spray Tips
			<ul style="list-style-type: none"> 2 Chemical Injector • Direct Drive

	<h2>9HP</h2>		Model# PE-3009RWCOMZ
			Engine 9HP Robin
Comet ZWD3030G 85.149.011B			Pump Comet
			Pressure 3,000 PSI
			Flow 3 GPM
			Weight 150 lbs
			Features
			<ul style="list-style-type: none"> • 9,000 Cleaning Units 2 Chemical Injector • EZstart Adjustable Unloader 3 50' Steel Braid Rubber Hose
			<ul style="list-style-type: none"> 1 Thermal Relief Valve 4 5,000 PSI Spray Gun • Safety Relief Valve 5 36" Insulated Lance
			<ul style="list-style-type: none"> • 13" Tubed Pneumatic Tires 6 4 Quick-Connect Spray Tips

	<h2>13.5HP</h2>		Model# PE-4013RWPCOM PE-4013RWPGEN
			Engine 13.5HP Robin 13.5HP Robin
Comet ZWD4040G 85.149.022B			Pump Comet General
			Pressure 4,000 PSI 4,000 PSI
General EZ4040G 85.139.021B			Flow 4 GPM 4 GPM
			Weight 175 lbs 175 lbs
			Features
			<ul style="list-style-type: none"> • 16,000 Cleaning Units 2 Chemical Injector • EZstart Adjustable Unloader 3 50' Steel Braid Rubber Hose
			<ul style="list-style-type: none"> 1 Thermal Relief Valve 4 5,000 PSI Spray Gun • Safety Relief Valve 5 36" Insulated Lance
			<ul style="list-style-type: none"> • 13" Tubed Pneumatic Tires 6 4 Quick-Connect Spray Tips



STAINLESS STEEL FRAMES

PACKAGING: Boxed

	<p>STAINLESS STEEL</p> <p>7HP</p>	<p>Model# PE-2570RWSCOM PE-2570RWGEN</p> <p>Engine 7HP Robin 7HP Robin</p> <p>Pump Comet General</p> <p>Pressure 2,500 PSI 2,500 PSI</p> <p>Flow 3 GPM 3 GPM</p> <p>Weight 105 lbs 105 lbs</p>	
	<p>Comet LWD-K3025G 85.149.015B</p>		<p>Features</p> <ul style="list-style-type: none"> • 7,500 Cleaning Units • Adjustable Unloader 1 Thermal Relief Valve 2 Chemical Injector
<p>General TP-2530 85.139.020B</p>	<p>1 Thermal Relief Valve</p>		

	<p>STAINLESS STEEL</p> <p>9HP</p>	<p>Model# PE-3009RWSCOMZ</p> <p>Engine 9HP Robin</p> <p>Pump Comet</p> <p>Pressure 3,000 PSI</p> <p>Flow 3 GPM</p> <p>Weight 150 lbs</p>	
	<p>Comet ZWD3030G 85.149.011B</p>		<p>Features</p> <ul style="list-style-type: none"> • 9,000 Cleaning Units • EZstart Adjustable Unloader 1 Thermal Relief Valve • Safety Relief Valve • 13" Tubed Pneumatic Tires
<p>General ZWD4040G 85.149.022B</p>	<p>1 Thermal Relief Valve</p>		

	<p>STAINLESS STEEL</p> <p>13.5HP</p>	<p>Model# PE-4013RWPSCOMZ PE-4013RWPSGEN</p> <p>Engine 13.5HP Robin 13.5HP Robin</p> <p>Pump Comet General</p> <p>Pressure 4,000 PSI 4,000 PSI</p> <p>Flow 4 GPM 4 GPM</p> <p>Weight 170 lbs 170 lbs</p>	
	<p>Comet ZWD4040G 85.149.022B</p>		<p>Features</p> <ul style="list-style-type: none"> • 16,000 Cleaning Units • EZstart Adjustable Unloader 1 Thermal Relief Valve • Safety Relief Valve • 13" Tubed Pneumatic Tires
<p>General EZ4040G 85.139.021B</p>	<p>1 Thermal Relief Valve</p>		



BLACK POWDER COATED FRAMES

PACKAGING: Boxed

PALLET PRICING

Purchase 8 or more 5HP models and receive special discounted pricing.



Comet AXD2523G
85.149.049B



85.490.042 optional
Pump anti-freeze.



Distinguishing Features

- A** Low Pressure Chemical Injector Kit
- B** Fully Adjustable Pressure
- C** 10" Tubed Pneumatic Tires



#	Model#	Engine	Pump	PSI	GPM	Weight
1	PE-2005HWCOMXE MODEL SHOWN	Honda 5.0 HP GC160	Comet AXD2523G	2,500	2.3	80 lbs

Pic	Feature	Pic	Feature	Pic	Feature
	• 5750 Cleaning Units	3	25' Steel Braided Rubber Hose		• Comet AXD2523G Pump
	• Honda 5.0 HP GC160 Gas Engine	4	2,750 PSI Front Entry Spray Gun		• Black Powder Coated Frame
1	10" Tubed Pneumatic Tires	5	36" Insulated Lance		• Direct Drive
2	Chemical Injector	6	4 Quick-Connect Spray Tips		• Box Dimensions: H19", L22½", W21"



HONDA
ENGINES

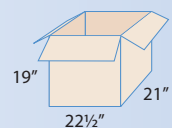

19" 21"
22½"



BLACK POWDER COATED FRAMES

PACKAGING: Boxed

PALLET PRICING

Purchase 8 or more 6HP models and receive special discounted pricing.



Comet AXD2527G
85.149.026B



85.490.042 optional
Pump anti-freeze.



Distinguishing Features

- A** Low Pressure Chemical Injector Kit
- B** Fully Adjustable Pressure
- C** 10" Tubed Pneumatic Tires



#	Model#	Engine	Pump	PSI	GPM	Weight
2	PE-2760HWC	Honda 6.0 HP GC190	Comet AXD2527G	2,700	2.5	80 lbs

Pic	Feature	Pic	Feature	Pic	Feature
	• 6,750 Cleaning Units	3	25' Steel Braided Rubber Hose		• Comet AXD2527G Pump
	• Honda 6.0 HP GC190 Gas Engine	4	5,000 PSI Spray Gun		• Black Powder Coated Frame
1	10" Tubed Pneumatic Tires	5	36" Insulated Lance		• Direct Drive
2	Chemical Injector	6	4 Quick-Connect Spray Tips		• Box Dimensions: H19", L22½", W21"



HONDA
ENGINES

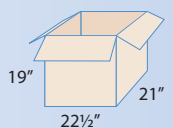



BLACK POWDER COATED FRAMES

PACKAGING: Boxed

PALLET PRICING

Purchase 4 or more 5.5HP models and receive special discounted pricing.



Distinguishing Features	
A	Honda GX Industrial Engine
B	Triplex Ceramic Piston Pump
C	10" Tubed Pneumatic Tires



#	Model#	Engine	Pump	PSI	GPM	Weight
3	PE-2055HWCAT MODEL SHOWN	Honda 5.5 HP GX160	Cat 2DX27GS	2,000	2.7	95 lbs
4	PE-2055HWCOM	Honda 5.5 HP GX160	Comet LWD-K3020G	2,000	3.0	95 lbs
5	PE-2055HWGEN	Honda 5.5 HP GX160	General TP-2530	2,000	3.0	95 lbs

Pic	Feature	Pic	Feature	Pic	Feature
	• 6,000 Cleaning Units	4	Chemical Injector		• Industrial Triplex Pump
	• Honda 5.5 HP GX160 Gas Engine	5	25' Steel Braided Rubber Hose		• Black Powder Coated Frame
1	Adjustable Unloader	6	5,000 PSI Spray Gun		• Direct Drive
2	10" Tubed Pneumatic Tires	7	36" Insulated Lance		• Box Dimensions: H19", L22½", W21
3	Thermal Relief Valve	8	4 Quick-Connect Spray Tips		



HONDA
ENGINES

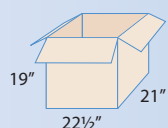



BLACK POWDER COATED FRAMES

PACKAGING: Boxed

PALLET PRICING

Purchase 4 or more 6.5HP models and receive special discounted pricing.



Comet LWD-K3025G
85.149.015B



General TP-2530
85.139.020B



Cat 3DX25
85.119.028B



Distinguishing Features

- A** Honda GX Industrial Engine
- B** Triplex Ceramic Piston Pump
- C** 10" Tubed Pneumatic Tires



#	Model#	Engine	Pump	PSI	GPM	Weight
6	PE-2565HWCAT	Honda 6.5 HP GX200	Cat 3DX25	2,500	3.0	95 lbs
7	PE-2565HWCOM MODEL SHOWN	Honda 6.5 HP GX200	Comet LWD-K3025G	2,500	3.0	95 lbs
8	PE-2565HWGEN	Honda 6.5 HP GX200	General TP-2530	2,500	3.0	95 lbs

Pic	Feature	Pic	Feature	Pic	Feature
	• 7,500 Cleaning Units	4	Chemical Injector		• Industrial Triplex Pump
	• Honda 6.5 HP GX200 Gas Engine	5	25' Steel Braided Rubber Hose		• Black Powder Coated Frame
1	Adjustable Unloader	6	5,000 PSI Spray Gun		• Direct Drive
2	Thermal Relief Valve	7	36" Insulated Lance		• Box Dimensions: H19", L22½", W21"
3	10" Tubed Pneumatic Tires	8	4 Quick-Connect Spray Tips		



HONDA
ENGINES

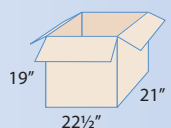



BLACK & RED POWDER COATED FRAMES

PACKAGING: Boxed

PALLET PRICING

Purchase 4 or more 9HP models and receive special discounted pricing.



Comet ZWD3030G
85.149.011B



85.490.042 optional
Pump anti-freeze.



Distinguishing Features

- A** Honda GX Industrial Engine
- B** Triplex Ceramic Piston Pump
- C** 13" Tubed Pneumatic Tires



#	Model#	Engine	Pump	PSI	GPM	Weight
9	PE-3009HWCOMZ MODEL SHOWN	Honda 9.0 HP GX270 (Oil Alert)	Comet ZWD3030G	3,000	3.0	165 lbs

Pic	Feature	Pic	Feature	Pic	Feature
	• 9,000 Cleaning Units	2	13" Tubed Pneumatic Tires	7	4 Quick-Connect Spray Tips
	• Honda 9 HP GX270 Gas Engine	3	Chemical Injector		• Comet ZWD3030G Pump
1	'EZ Start' Adjustable Unloader • Thermal Relief Valve (145°) • Safety Relief Valve	4	50' Steel Braided Rubber Hose		• Black & Red Powder Coated Frame
		5	5,000 PSI Spray Gun		• Direct Drive
		6	36" Insulated Lance		• Box Dimensions: H25" L31" W24"



**HONDA
ENGINES**

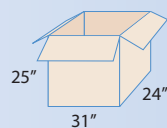



BLACK & RED POWDER COATED FRAMES

PACKAGING: Boxed

PALLET PRICING

Purchase 4 or more 11HP models and receive special discounted pricing.

Cat 66DX40
85.119.014B



Comet ZWD4030G
85.149.012B



General TX1510G8
85.139.002B



Distinguishing Features

- A** Honda GX Industrial Engine
- B** Triplex Ceramic Piston Pump
- C** 13" Tubed Pneumatic Tires

#	Model#	Engine	Pump	PSI	GPM	Weight
10	PE-3011HWCAT MODEL SHOWN	Honda 11 HP GX340 (Oil Alert)	Cat 66DX40	3,000	4.0	165 lbs
11	PE-3011HWCOMZ	Honda 11 HP GX340 (Oil Alert)	Comet ZWD4030G	3,000	4.0	165 lbs
12	PE-3011HWGEN	Honda 11 HP GX340 (Oil Alert)	General TX1510G8	3,000	4.0	165 lbs

Pic	Feature	Pic	Feature	Pic	Feature
	• 12,000 Cleaning Units	2	13" Tubed Pneumatic Tires	7	4 Quick-Connect Spray Tips
	• Honda 11 HP GX340 Gas Engine	3	Chemical Injector		• Industrial Triplex Pump
1	'EZ Start' Adjustable Unloader • Thermal Relief Valve (145°) • Safety Relief Valve	4	50' Steel Braided Rubber Hose		• Black & Red Powder Coated Frame
		5	5,000 PSI Spray Gun		• Direct Drive
		6	36" Insulated Lance		• Box Dimensions: H25", L31", W24"



HONDA
ENGINES

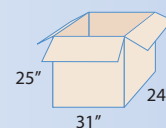



BLACK & RED POWDER COATED FRAMES

PACKAGING: Boxed

PALLET PRICING

Purchase 4 or more 13HP models and receive special discounted pricing.



Cat 66DX35
85.119.025B



Comet ZWD4040G
85.149.022B



General EZ4040G
85.139.021B



Distinguishing Features

- A** Honda GX Industrial Engine
- B** Triplex Ceramic Piston Pump
- C** 13" Pneumatic Tires



#	Model#	Engine	Pump	PSI	GPM	Weight
13	PE-4013HWPCAT	Honda 13 HP GX390 Pull Start (Oil Alert)	Cat 66DX35	4,000	3.5	175 lbs
14	PE-4013HWPCOMZ	Honda 13 HP GX390 Pull Start MODEL SHOWN	Comet ZWD4040G	4,000	4.0	175 lbs
15	PE-4013HWPGEN	Honda 13 HP GX390 Pull Start (Oil Alert)	General EZ4040G	4,000	4.0	175 lbs
16	PE-4013HWECAT	Honda 13 HP GX390 Electric Start (Oil Alert)	Cat 66DX35	4,000	3.5	175 lbs
17	PE-4013HWECOMZ	Honda 13 HP GX390 Electric Start (Oil Alert)	Comet ZWD4040G	4,000	4.0	175 lbs
18	PE-4013HWEGEN	Honda 13 HP GX390 Electric Start (Oil Alert)	General EZ4040G	4,000	4.0	175 lbs

Pic	Feature	Pic	Feature	Pic	Feature
	• 16,000 Cleaning Units	2	13" Tubed Pneumatic Tires	7	4 Quick-Connect Spray Tips
	• Honda 13 HP GX390 Gas Engine	3	Chemical Injector		• Industrial Triplex Pump
1	'EZ Start' Adjustable Unloader	4	50' Steel Braided Non Marking Hose		• Black & Red Powder Coated Frame
	• Thermal Relief Valve (145°)	5	5,000 PSI Spray Gun		• Direct Drive
	• Safety Relief Valve	6	36" Insulated Lance		• Box Dimensions: H25", L31", W24"



HONDA
ENGINES

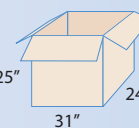

31"



ROBIN SUBARU ENGINES

PACKAGING: Boxed

7HP ROBIN ENGINE, EX21

Overhead Cam Engine



Model#	85.520.070
Horse Power	7HP
RPM	3400 - 3600
Shaft	3/4" Keyed

Overhead Cam Engine

9HP ROBIN ENGINE, EX27

Overhead Cam Engine



Model#	85.520.090
Horse Power	9HP
RPM	3400 - 3600
Shaft	1" Keyed

Overhead Cam Engine

13.5HP ROBIN ENGINE, EH41

Overhead Valve Engine



Model#	85.520.130
Horse Power	13.5HP
RPM	3400 - 3600
Shaft	1" Keyed

Overhead Valve Engine

BASE PLATES

Turn any Power Washer into a truck or trailer mount unit.
Has 4 rubber feet that can be bolted through to mount to trailer bottom.

Sample base plate mount



Model#	85.600.016
Dimensions	W13.625" x L18.125" x H1.75"



STAINLESS STEEL COMPACT FRAMES

PACKAGING: Boxed

PALLET PRICING

Purchase 4 or more 5.5HP models and receive special discounted pricing.

STAINLESS STEEL



Comet LWD-K3020G
85.149.009B



General TP-2530
85.139.020B



Cat 2DX27GS
85.119.018B

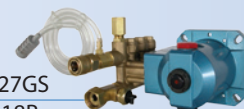

Distinguishing Features

- A** Stainless Steel Compact Frame
- B** 50' Steel Braided Rubber Hose
- C** Thermal Pump Protection



#	Model#	Engine	Pump	PSI	GPM	Weight
19	PE-2055HWSCAT MODEL SHOWN	Honda 5.5 HP GX160	Cat 2DX27GS	2,000	2.7	105 lbs
20	PE-2055HWSCOM	Honda 5.5 HP GX160	Comet LWD-K3020G	2,000	3.0	105 lbs
21	PE-2055HWSGEN	Honda 5.5 HP GX160	General TP-2530	2,000	3.0	105 lbs

Pic	Feature	Pic	Feature	Pic	Feature
	• 6,000 Cleaning Units	4	Chemical Injector		• Industrial Triplex Pump
	• Honda 5.5 HP GX160 Gas Engine	5	50' Steel Braided Rubber Hose		• Stainless Steel Compact Frame
1	Adjustable Unloader	6	5,000 PSI Spray Gun		• Direct Drive
2	Thermal Relief Valve	7	36" Insulated Lance		• Box Dimensions: H20", L24½", W24"
3	10" Tubed Pneumatic Tires	8	4 Quick-Connect Spray Tips		



**HONDA
ENGINES**

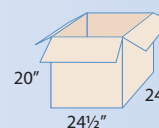



STAINLESS STEEL COMPACT FRAMES

PACKAGING: Boxed

PALLET PRICING

Purchase 4 or more 6.5HP models and receive special discounted pricing.

STAINLESS STEEL



Comet LWD-K3025G
85.149.015B



General TP-2530
85.139.020B



Cat 3DX
85.119.028B



Distinguishing Features

- A** Stainless Steel Compact Frame
- B** 50' Steel Braided Rubber Hose
- C** Thermal Pump Protection

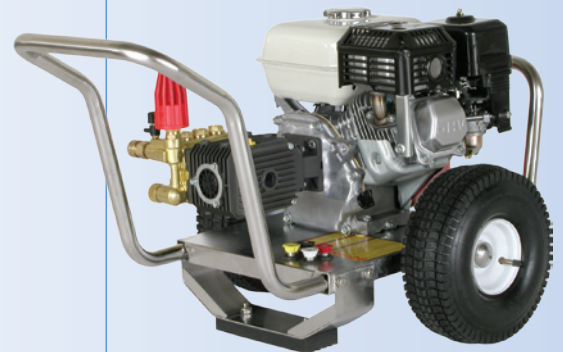

#	Model#	Engine	Pump	PSI	GPM	Weight
22	PE-2565HWSCAT	Honda 6.5 HP GX200	Cat 3DX	2,500	3.0	105 lbs
23	PE-2565HWSCOM MODEL SHOWN	Honda 6.5 HP GX200	Comet LWD-K3025G	2,500	3.0	105 lbs
24	PE-2565HWSGEN	Honda 6.5 HP GX200	General TP-2530	2,500	3.0	105 lbs

Pic	Feature	Pic	Feature	Pic	Feature
	• 7,500 Cleaning Units	4	Chemical Injector		• Industrial Triplex Pump
	• Honda 6.5 HP GX200 Gas Engine	5	50' Steel Braided Rubber Hose		• Stainless Steel Compact Frame
1	Adjustable Unloader	6	5,000 PSI Spray Gun		• Direct Drive
2	Thermal Relief Valve	7	36" Insulated Lance		• Box Dimensions: H20", L24½", W24"
3	10" Tubed Pneumatic Tires	8	4 Quick-Connect Spray Tips		



HONDA
ENGINES

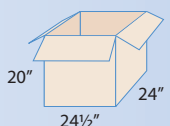



STAINLESS STEEL COMPACT FRAMES

PACKAGING: Boxed

PALLET PRICING

Purchase 4 or more 9HP models and receive special discounted pricing.

STAINLESS STEEL



Comet ZWD3030G
85.149.011B



Distinguishing Features

- A Stainless Steel Compact Frame
- B 50' Steel Braided Rubber Hose
- C Thermal Pump Protection

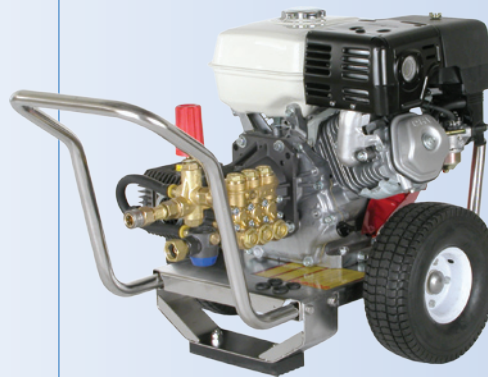

#	Model#	Engine	Pump	PSI	GPM	Weight
25	PE-3009HWCCOMZ MODEL SHOWN	9HP Honda GX270	Comet ZWD3030G	3,000	3.0	130 lbs

Pic	Feature	Pic	Feature	Pic	Feature
	• 9,000 Cleaning Units	4	Chemical Injector		• Comet ZWD3030G
	• Honda 9 HP GX270 Gas Engine	5	50' Steel Braided Rubber Hose		• Stainless Steel Compact Frame
1	Adjustable Unloader	6	5,000 PSI Spray Gun		• Direct Drive
2	Thermal Relief Valve	7	36" Insulated Lance		• Box Dimensions: H20", L24½", W24"
3	10" Tubed Pneumatic Tires	8	4 Quick-Connect Spray Tips		



HONDA
ENGINES

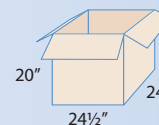



STAINLESS STEEL FRAMES

PACKAGING: Boxed

PALLET PRICING

Purchase 4 or more 9HP models and receive special discounted pricing.

STAINLESS STEEL



Comet ZWD3030G
85.149.011B



Distinguishing Features

- A** Stainless Steel Frame
- B** Vibration Dampeners
- C** 13" Tubed Pneumatic Tires



#	Model#	Engine	Pump	PSI	GPM	Weight
26	PE-3009HWSOMZ	MODEL SHOWN 9HP Honda GX270	Comet ZWD3030G	3,000	3.0	150 lbs

Pic	Feature	Pic	Feature	Pic	Feature
	• 9,000 Cleaning Units	2	13" Tubed Pneumatic Tires	7	4 Quick-Connect Spray Tips
	• Honda 9 HP GX270 Gas Engine	3	Chemical Injector		• Comet ZWD3030G
1	'EZ Start' Adjustable Unloader	4	50' Steel Braided Non Marking Hose		• Stainless Steel Frame
	• Thermal Relief Valve (145°)	5	5,000 PSI Spray Gun		• Direct Drive
	• Safety Relief Valve	6	36" Insulated Lance		• Box Dimensions: H27", L33", W27"



**HONDA
ENGINES**

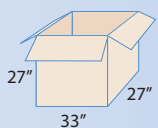

33"



STAINLESS STEEL FRAMES

PACKAGING: Boxed

PALLET PRICING

Purchase 4 or more 11HP models and receive special discounted pricing.

STAINLESS STEEL



Cat 66DX40
85.119.014B

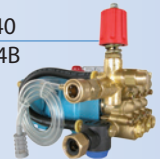

Comet ZWD4030G
85.149.012B



General TX1510
85.139.002B



Distinguishing Features

- A Stainless Steel Frame
- B Vibration Dampeners
- C 13" Tubed Pneumatic Tires



#	Model#	Engine	Pump	PSI	GPM	Weight
27	PE-3011HWSCAT	Honda 11 HP GX340	Cat 66DX40	3,000	4.0	160 lbs
28	PE-3011HWSCOMZ	Honda 11 HP GX340	Comet ZWD4030G	3,000	4.0	160 lbs
29	PE-3011HWSGEN	Honda 11 HP GX340	General TX1510	3,000	4.0	160 lbs

Pic	Feature	Pic	Feature	Pic	Feature
	• 12,000 Cleaning Units	2	13" Tubed Pneumatic Tires	7	4 Quick-Connect Spray Tips
	• Honda 11 HP GX340 Gas Engine	3	Chemical Injector		• Industrial Triplex Pump
1	'EZ Start' Adjustable Unloader	4	50' Steel Braided Non Marking Hose		• Stainless Steel Frame
	• Thermal Relief Valve (145°)	5	5,000 PSI Spray Gun		• Direct Drive
	• Safety Relief Valve	6	36" Insulated Lance		• Box Dimensions: H27", L33", W27"



**HONDA
ENGINES**

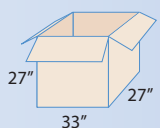



STAINLESS STEEL FRAMES

PACKAGING: Boxed

PALLET PRICING

Purchase 4 or more 13HP models and receive special discounted pricing.

STAINLESS STEEL

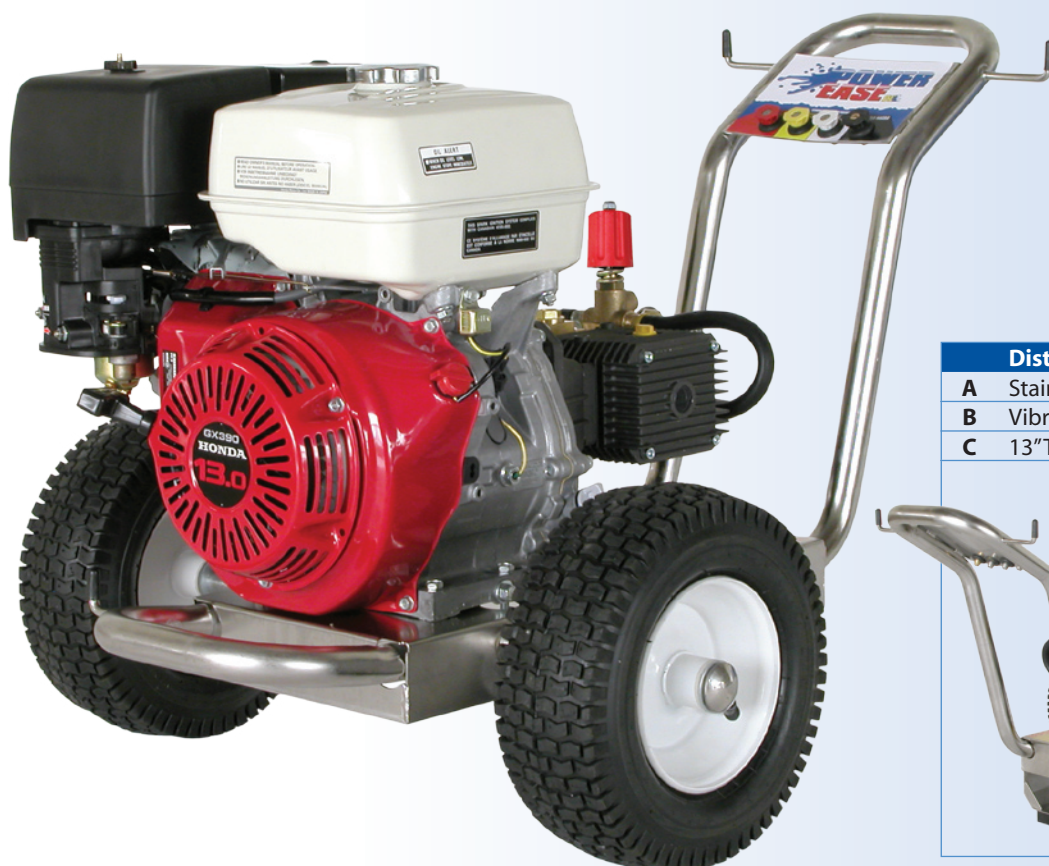

Cat 66DX35
85.119.025AB



Comet ZWD4040G
85.149.022AB



General EZ4040
85.139.021AB



Distinguishing Features

- A** Stainless Steel Frame
- B** Vibration Dampeners
- C** 13" Tubed Pneumatic Tires



#	Model#	Engine	Pump	PSI	GPM	Weight
30	PE-4013HWPCAT	Honda 13 HP GX390	Cat 66DX35	4,000	3.5	160 lbs
31	PE-4013HWPCOMZ MODEL SHOWN	Honda 13 HP GX390	Comet ZWD4040G	4,000	4.0	160 lbs
32	PE-4013HWPSGEN	Honda 13 HP GX390	General EZ4040	4,000	4.0	160 lbs

Pic	Feature	Pic	Feature	Pic	Feature
	• 16,000 Cleaning Units	2	13" Tubed Pneumatic Tires	7	4 Quick-Connect Spray Tips
	• Honda 13 HP GX390 Gas Engine	3	Chemical Injector		• Industrial Triplex Pump
1	'EZ Start' Adjustable Unloader	4	50' Steel Braided Non Marking Hose		• Stainless Steel Frame
	• Thermal Relief Valve (145°)	5	5,000 PSI Spray Gun		• Direct Drive
	• Safety Relief Valve	6	36" Insulated Lance		• Box Dimensions: H27", L33", W27"



HONDA
ENGINES

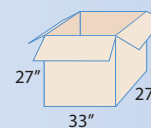



STAINLESS STEEL FRAMES

PACKAGING: Boxed

PALLET PRICING

Purchase 4 or more 13HP models and receive special discounted pricing.

STAINLESS STEEL

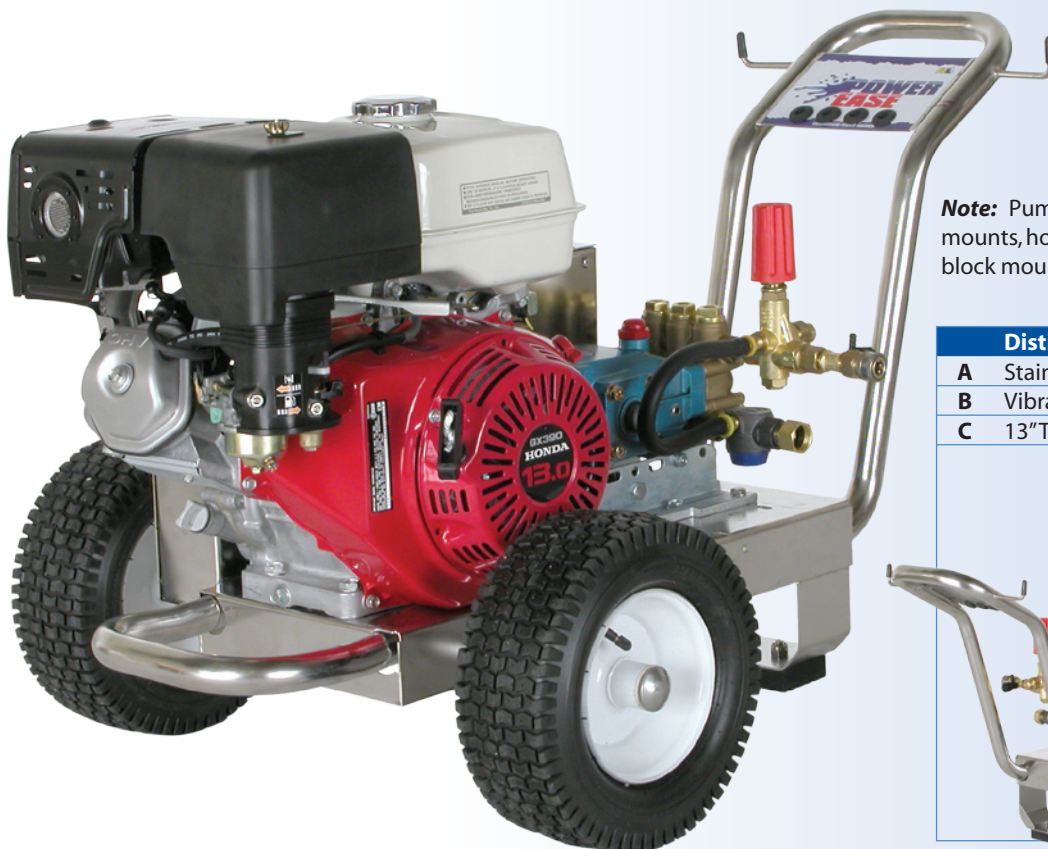

Cat 5CP3120
85.119.021AB



Comet HWS3540
85.149.031AB



General TS1511
85.139.005AB



Note: Pumps above are shown with block mounts, however, this unit does not utilize the block mount.

Distinguishing Features

- A** Stainless Steel Frame
- B** Vibration Dampeners
- C** 13" Tubed Pneumatic Tires



#	Model#	Engine	Pump	PSI	GPM	Weight
33	PE-3513HWBSCAT MODEL SHOWN	Honda 13 HP GX390 Oil Alert	Cat 5CP3120	3,500	4.0	200 lbs
34	PE-4013HWBSCOMA	Honda 13 HP GX390 Oil Alert	Comet HWS3540	4,000	3.5	200 lbs
35	PE-3513HWBSGEN	Honda 13 HP GX390 Oil Alert	General TS1511	3,500	4.0	200 lbs

Pic	Feature	Pic	Feature	Pic	Feature
	• 14,000 Cleaning Units	2	13" Tubed Pneumatic Tires	7	4 Quick-Connect Spray Tips
	• Honda 13 HP GX390 Gas Engine	3	Chemical Injector		• Industrial Triplex Pump
1	'EZ Start' Adjustable Unloader • Thermal Relief Valve (145°) • Safety Relief Valve	4	50' Steel Braided Non Marking Hose		• Stainless Steel Frame
		5	5,000 PSI Spray Gun		• Belt Drive
		6	36" Insulated Lance		• Box Dimensions: H27", L33", W27"



**HONDA
ENGINES**

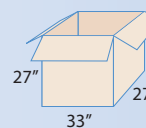

33"

1-800-663-8331

Address

http://www.bepressure.com/



Go

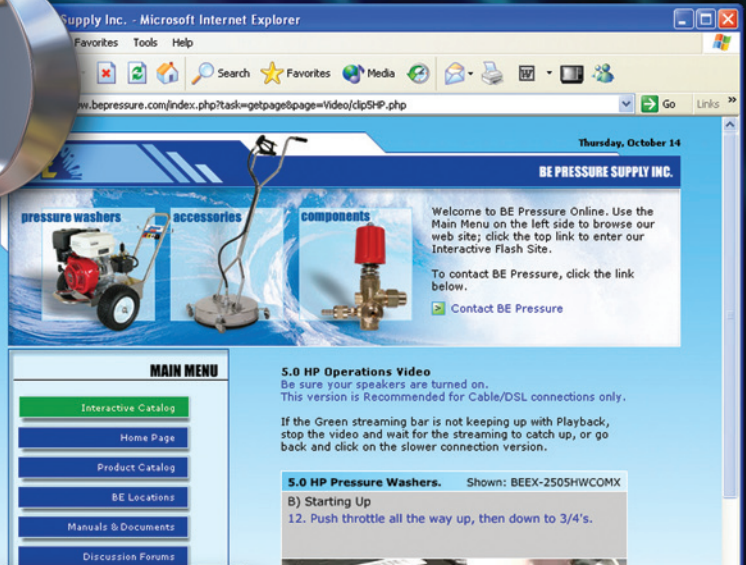

MORE TO DISCOVER AND MUCH MORE ON ITS WAY AT www.BEPRESSURE.com

1. View product demonstrations and step-by-step tutorial **Videos** online.
2. Discuss field topics and trouble-shooting in our interactive **Discussion Forums**.
3. Create custom print pages using our **Interactive Catalog** and **Brochure Creator**.

COOLDRIVE

Pic SPECIAL FEATURE

- 1** AIR VENTS. Cool air is drawn into the unit through the outer air vents.
- 2** PULLEY SYSTEM. Laser aligned patented pulley fanning system creates cooling air flow.
- 3** COOLER PUMP. Cool air is propelled over the pump, reducing the heat by 25%.
- 4** FREE STANDING GUARD. Guard is not attached to the engine, resulting in 45% less vibration.

Pic SPECIAL FEATURE

- 5** QUICK REMOVE COVER. Stainless steel belt guard removes easily in 20 seconds with 3 hand-tightening knobs. No tools are required.
- 6** FOAM FILLED TIRES. Flat-Free no air tires.
- 7** ALUMINUM MAGS. Industrial strength aluminum mags.

IT'S FINALLY HERE!...
RUNNING 25% COOLER THAN ANY BELT DRIVE



RESULTING IN 25% MORE PUMP LIFE



COOLDRIVE STAINLESS STEEL FRAME

PACKAGING: Boxed

Cat 5CP3120
85.119.021B



Comet HWS3540
85.149.031B



General TS1511
85.139.005B



PALLET PRICING

Purchase 4 or more Cooldrive models and receive special discounted pricing.

STAINLESS STEEL

COOLDRIVE

Distinguishing Features

- 1 Patented Cooling Technology
- 2 Cool Air Ventilation Slots
- 3 Perm-A-Line Belt Tension System
- 4 Laser Aligned Pulley Fanning System
- 5 Quick-Release Belt Guard Knobs
- 6 Free Standing S.Steel Belt Guard
- 7 Flat-Free Foam Filled Tires
- 8 Industrial Aluminum Mags
- 9 Block Mounted Unloader



#	Model#	Engine	Pump	PSI	GPM	Weight
36	CD-3513HWBSCAT	Honda 13 HP GX390 Oil Alert	Cat 5CP3120	3,500	4.0	210 lbs
37	CD-4013HWBSCOMA MODEL SHOWN	Honda 13 HP GX390 Oil Alert	Comet HWS3540	4,000	3.5	210 lbs
38	CD-3513HWBGEN	Honda 13 HP GX390 Oil Alert	General TS1511	3,500	4.0	210 lbs

Pic	Feature	Pic	Feature	Pic	Feature
	• 14,000 Cleaning Units	2	13" Foam Filled Tires	7	4 Quick-Connect Spray Tips
	• Honda 13 HP GX390 Gas Engine	3	Chemical Injector		• Industrial Triplex Pump
1	'EZ Start' Adjustable Unloader	4	50' Steel Braided Non-Marking Hose		• Stainless Steel Frame
	• Thermal Relief Valve (145°)	5	5,000 PSI Spray Gun		• Belt Drive
	• Safety Relief Valve	6	36" Insulated Lance		• Box Dimensions: H27", L33", W27"



HONDA
ENGINES

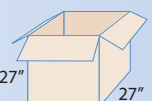

33"



STAINLESS STEEL 4 WHEEL FRAME

PACKAGING: Strapped & Wrapped on Pallet



Comet
TW5050S
85.149.059B



Comet
HWS5040S
85.149.030B

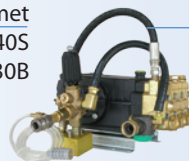

General
TS2021
85.139.026B



General
T5050
85.139.018B

STAINLESS STEEL



Distinguishing Features

- A** All Stainless Roll Cage Frame
- B** Large 4 Gallon Top Mount Gas Tank
- C** Electric Start Honda GX Engine
- D** Belt Drive

#	Model#	Engine	Pump	PSI	GPM	Weight
39	PE-4020HWEBSKOM	Honda Electric Start 20 HP GX620	Comet HWS5040S	4,000	5.3	290 lbs
40	PE-4020HWEBSGEN	Honda Electric Start 20 HP GX620	General TS2021	3,500	5.6	290 lbs
41	PE-5024HWEBSKOM	Honda Electric Start 24 HP GX670	Comet TW5050	5,000	5.0	290 lbs
42	PE-5024HWEBSGEN MODEL SHOWN	Honda Electric Start 24 HP GX670	General T5050	5,000	5.0	290 lbs

Pic	Feature	Pic	Feature	Pic	Feature
	• 19,600-25,000 Cleaning units	4	4 x 13" Tubed Pneumatic Tires	9	4 Quick-Connect Spray Tips
	• Honda 20-24 HP Gas Engine	5	Chemical Injector		• 4 Gallon Gas Tank
1	'Adjustable Unloader	6	50' Steel Braided Rubber Hose		• Industrial Triplex Pump
2	Thermal Relief Valve (145°)	7	5,000 PSI Spray Gun		• Stainless Steel Frame
3	Safety Relief Valve	8	36" Insulated Lance		• Belt Drive



**HONDA
ENGINES**



STAINLESS STEEL FRAMES GEARDRIVE

PACKAGING: Strapped & Wrapped on Pallet



THE FIRST TRUE BUMPER-TO-BUMPER WARRANTY

- Die cast aluminum alloy crank case for protection again corrosion.
- Piston guides are heat treated stainless steel.
- Stainless steel check valves.
- Single piece, solid bronze alloy connecting rods.

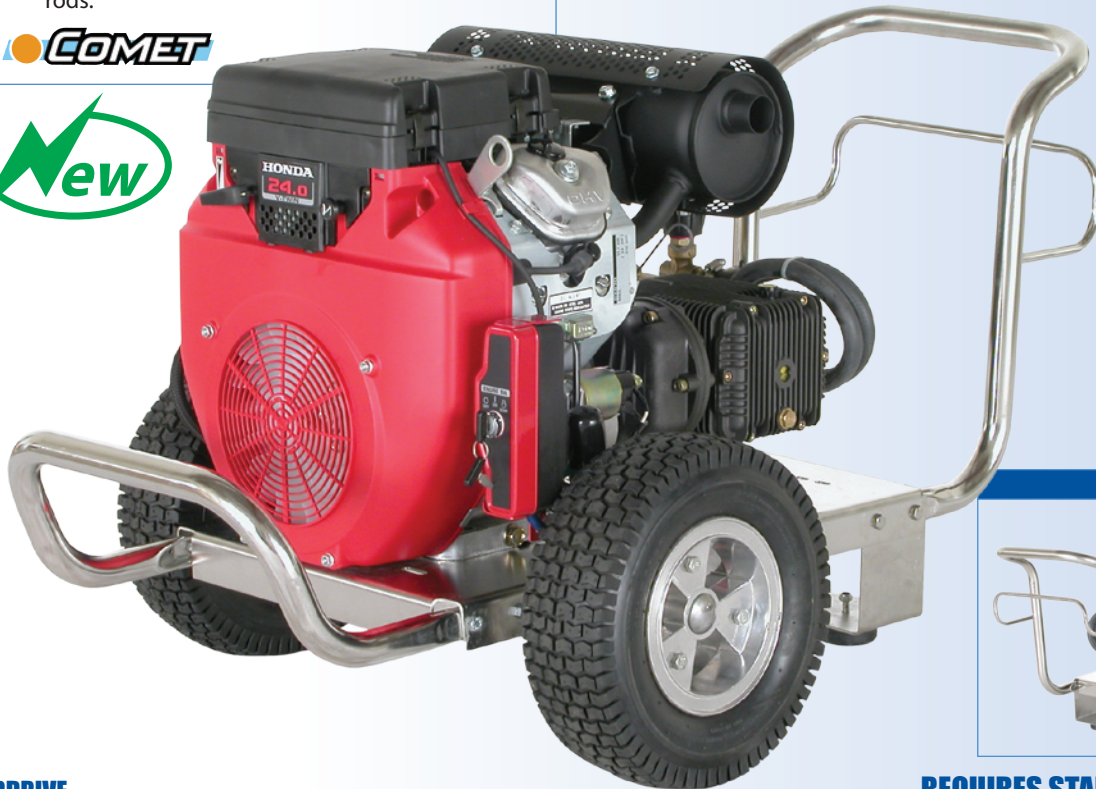

Comet
TW5050S
85.149.059B

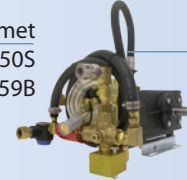

General
T5050
85.139.018B

STAINLESS STEEL

Back Side



GEARDRIVE

REQUIRES STAND-ALONE GAS TANK

#	Model#	Engine	Pump	PSI	GPM	Weight
43	PE-4220HWEGSCOM	Honda Electric Start 20 HP GX620	Comet TW5050S	4,200	5.0	250 lbs
44	PE-4220HWEGSGEN	Honda Electric Start 20 HP GX620	General T5050	4,200	5.0	250 lbs
45	PE-5024HWEGSCOM MODEL SHOWN	Honda Electric Start 24 HP GX670	Comet TW5050S	5,000	5.0	250 lbs
46	PE-5024HWEGSGEN	Honda Electric Start 24 HP GX670	General T5050	5,000	5.0	250 lbs

Pic	Feature	Pic	Feature	Pic	Feature
	• 21,000-25,000 Cleaning units	4	13" Foam Filled Tires/Alum. Mags	9	4 Quick-Connect Spray Tips
	• Honda 20-24 HP Gas Engine	5	Chemical Injector		• Industrial Triplex Pump
1	Adjustable Unloader	6	50' Steel Braided Rubber Hose		• Stainless Steel Frame
2	Thermal Relief Valve (145°)	7	5,000 PSI Spray Gun		• Gearbox Drive
3	Safety Relief Valve	8	36" Insulated Lance		





BLACK POWDER COATED FRAMES

PACKAGING: Boxed

PALLET PRICING

Purchase 4 or more 1.5HP models and receive special discounted pricing.



CSA Approved Units



INCLUDES A GFCI (GROUND FAULT CIRCUIT INTERRUPTOR) 23 FT. 12 GAUGE CORD

Comet AXD2010E
85.149.024B

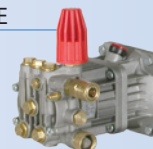

Comet LWD-K2020E
85.149.021B



Cat2DX20E
85.119.019B



Distinguishing Features

- A** 10" Tubed Pneumatic Tires
- B** 25' Steel Braided Rubber Hose
- C** Industrial Baldor Motor



#	Model#	Engine	Pump	PSI	GPM	Weight
47	PE-1115EW1COM MODEL SHOWN	1.5 HP (1 phase) 110V	Comet LWD-K2020E	1,100	2.0	95 lbs
48	PE-1115EW1COMX	1.5 HP (1 phase) 110V	Comet AXD2010E	1,100	2.0	95 lbs
49	PE-1115EW1CAT	1.5 HP (1 phase) 110V	Cat2DX20E	1,100	2.0	95 lbs

Pic	Feature	Pic	Feature	Pic	Feature
	• 2,200 Cleaning Units	3	25' Steel Braided Rubber Hose		• Switch, Cord & Plug Included
	• Baldor Electric Motor 1.5 HP	4	4,000 PSI Spray Gun		• Black Powder Coated Frame
1	10" Tubed Pneumatic Tires	5	36" Insulated Lance		• Box Dimensions: H19", L22½", W21"
2	Chemical Injector	6	4 Quick-Connect Spray Tips		

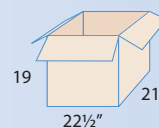



BLACK POWDER COATED FRAMES

PACKAGING: Boxed

PALLET PRICING

Purchase 4 or more 2.0HP models and receive special discounted pricing.



CSA Approved Units



INCLUDES A GFCI (GROUND FAULT CIRCUIT INTERRUPTOR) 23 FT. 12 GAUGE CORD

Comet AXD2010E
85.149.024B

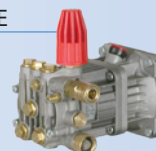

Comet LWD-K2020E
85.149.021B



Cat2DX20E
85.119.019B



Distinguishing Features

- A** 10" Tubed Pneumatic Tires
- B** 25' Steel Braided Rubber Hose
- C** Industrial Baldor Motor



#	Model#	Engine	Pump	PSI	GPM	Weight
50	PE-1520EW1COM	2.0 HP (1 phase) 110V	Comet LWD-K2020E	1,500	2.0	100 lbs
51	PE-1520EW1COMX MODEL SHOWN	2.0 HP (1 phase) 110V	Comet AXD2010E	1,500	2.0	100 lbs
52	PE-1520EW1CAT	2.0 HP (1 phase) 110V	Cat2DX20E	1,500	2.0	100 lbs

Pic	Feature	Pic	Feature	Pic	Feature
	• 3,000 Cleaning Units	3	25' Steel Braided Rubber Hose		• Switch, Cord & Plug Included
	• Baldor Electric Motor 2.0 HP	4	4,000 PSI Spray Gun		• Black Powder Coated Frame
1	10" Tubed Pneumatic Tires	5	36" Insulated Lance		• Box Dimensions: H19", L22½", W21"
2	Chemical Injector	6	4 Quick-Connect Spray Tips		

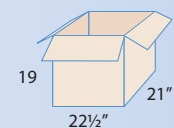



BLACK & RED POWDER COATED FRAMES

PACKAGING: Boxed

PALLET PRICING

Purchase 4 or more electric models and receive special discounted pricing.



DOES NOT INCLUDE SWITCH, CORD & PLUG



Comet LWD-K2020E
85.149.021B



Comet FWS3530E
85.149.017B



Comet FWS4030E
85.149.008B

Distinguishing Features

- A** Oversized Powder Coated Frame
- B** Industrial Grade Pump and Motor
- C** Rubber Vibration Dampeners



#	Model#	Engine	Pump	PSI	GPM	Weight
53	PE-2030EW1COM	3.0 HP (1 phase) 220V	Comet LWD-K2020E	2,000	2.2	135 lbs
54	PE-2050EW1COM	5.0 HP (1 phase) 220V	Comet FWS3530E	2,000	3.5	200 lbs
55	PE-2050EW3COM	5.0 HP (3 phase) 575V	Comet FWS3530E	2,000	3.5	200 lbs
56	PE-2775EW1COM MODEL SHOWN	7.5 HP (1 phase) 220V	Comet FWS3530E	2,700	3.5	230 lbs
57	PE-2775EW3COM	7.5 HP (3 phase) 575V	Comet FWS3530E	2,700	3.5	230 lbs
58	PE-3010EW3COM	10 HP (3 phase) 575V	Comet FWS4030E	3,000	4.0	230 lbs
59	PE-2050EW3COM4	5.0 HP (3 phase) 460V	Comet FWS3530E	2,000	3.5	200 lbs
60	PE-2775EW3COM4	7.5 HP (3 phase) 460V	Comet FWS3530E	2,700	3.5	230 lbs
61	PE-3010EW3COM4	10 HP (3 phase) 460V	Comet FWS4030E	3,000	4.0	230 lbs

Pic	Feature	Pic	Feature	Pic	Feature
	4,400 - 12,000 Cleaning Units		50' Steel Braided Rubber Hose		Black/Red Powder Coated Frame
	Baldor Electric Motor		5,000 PSI Spray Gun		Direct Drive
	1 Thermal Relief Valve (145°)		36" Insulated Lance		Box Dimensions: H25", L31", W24"
	2 13" Tubed Pneumatic Tires		4 Quick-Connect Spray Tips		
	3 Chemical Injector		Does not include Cord, Switch or Plug		

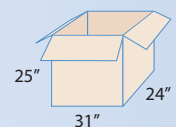



RED POWDER COATED PACK-A-ROUND FRAMES

PACKAGING: Boxed

Unit starts automatically when trigger is pulled, and shuts down automatically when trigger is released.

Comet LWD-K2020E
85.149.021B



Example of Pack-A-Round mounted to a wall.

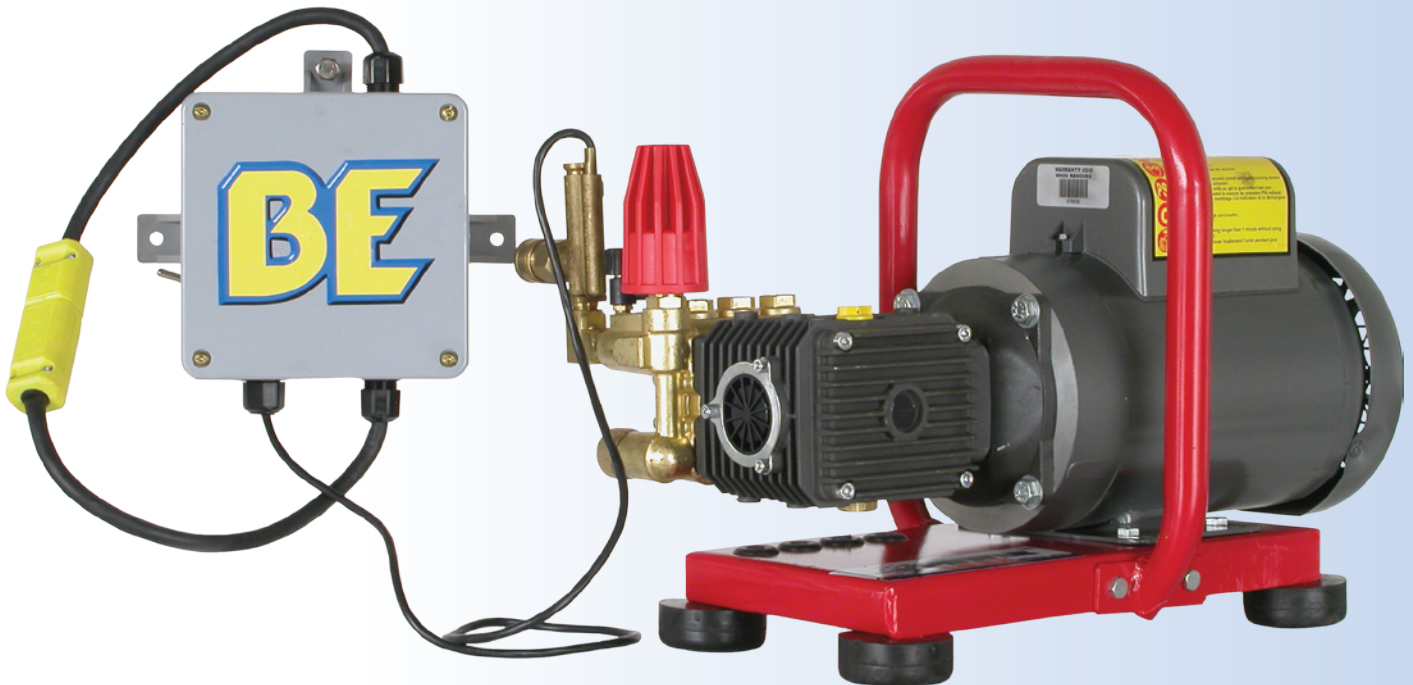

#	Model#	Engine	Pump	PSI	GPM	Weight
62	PE-1520EP1COMH MODEL SHOWN	2.0 HP (1 phase) 110V	Comet LWD-K2020E	1,500	2.0	80 lbs

Pic	Feature	Pic	Feature	Pic	Feature
	• 3,000 Cleaning Units	3	5,000 PSI Spray Gun		• Comet LWD-K2020E Pump
	• Baldor Electric Motor	4	36" Insulated Lance		• Red Powder Coated Frame
1	Chemical Injector	5	4 Quick-Connect Spray Tips		• Box Dimensions: H24½", L32", W25"
2	25' Steel Braided Rubber Hose	6	Auto Switch Box		

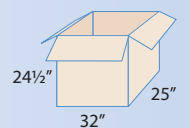



**WHEN YOU
NEED POWER...**



POWER EASE PREMIUM GENERATOR SERIES

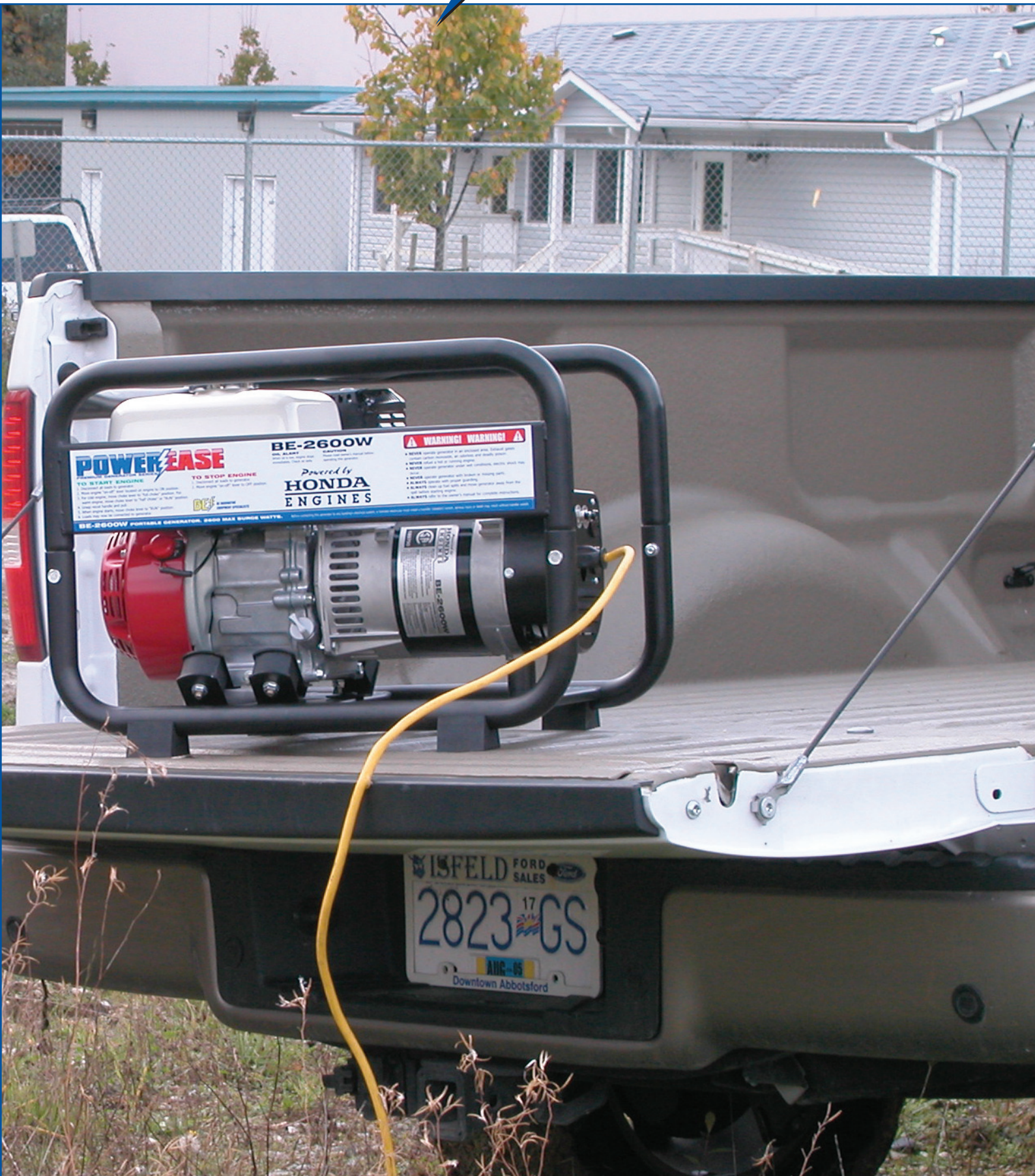

POWER EASE
BE-2600W
WARNING! WARNING!
Powered by
HONDA
ENGINES
BE-2600W PORTABLE GENERATOR, 2600 MAX BURGE WATTS.

TO START ENGINE
1. Turn on the fuel valve.
2. Turn the engine switch to the "ON" position.
3. Push the starter button.
4. If the engine does not start, wait 10 seconds and try again.
5. Do not touch the engine or any moving parts.
6. Do not touch the generator while it is running.
7. Do not touch the generator while it is running.

TO STOP ENGINE
1. Turn the engine switch to the "OFF" position.
2. Turn off the fuel valve.

- NEVER operate generator in an enclosed area. Exhaust gases are poisonous, flammable and deadly.
- NEVER refuel a hot or running engine.
- NEVER connect generator under wet conditions, never place over water.
- NEVER operate generator with broken or missing parts.
- NEVER operate with ground faulting.
- NEVER touch any hot parts and move generator away from the hot surface during engine.
- ALWAYS refer to the owner's manual for complete instructions.

ISFELD FORD SALES
2823 17 GS
ANG-65
Downtown Abbotsford



PACKAGING: Boxed

POWER EASE

PREMIUM
GENERATOR
SERIES



Powered by
HONDA
ENGINES



Excellent for Emergency Back Up and Camping.

- Overhead valve engine provides improved fuel efficiency, longer life, easier maintenance and less noise.
- 1.82 Quart gas tank provides up to 2 hours run time at 50% load.
- 4 x 120 volt outlets with circuit breaker protection.
- Brushless generator head is maintenance-free
- **Optional wheel kit, includes handle. part# 85.400.029**



Sample Applications	Watts (running)	Watts (max)
Elec. Range	1500	1500
Freezer	400	600
Refrigerator	600	800-2000
Television	300	300
Microwave	625	800
Coffee Maker	850	1500
Circular Saw 6.5"	800	1200
Hand Drill	250	1000

Distinguishing Features

- A** Brushless Generator Head
- B** Maintenance Free
- C** 4 x 120V Receptacles



Model#	Engine	Maximum Output	Continuous Output	Voltage	Weight
BE-2600W	5 HP Honda GC160, Oil Alert	2600 Watts	2100 Watts	120V	88 lbs

Feature	Feature	Feature
• 5 HP Honda GC160, Oil Alert	• Single Phase	• Black Powder Coated Frame
• 2600 Watts Maximum	• 4 x 120V Receptacles	• Box Dimensions: H25", L31", W24"
• 2100 Watts Continuous	• 60 Hertz	Optional wheel kit, includes handle. part# 85.400.029
• 120 Volts	• Brushless Generator Head	



PACKAGING: Boxed

POWER EASE

INDUSTRIAL GENERATOR SERIES



GENERATOR 5.5 HP

Optional wheel kit part# 85.400.029



Model#	BE-2900W
Engine	5.5 HP Honda GX160, Oil Alert
Max Output	2,900 Watts
Continuous Output	2,400 Watts
Voltage	120V/240V
Recepticles	120V Duplex, 240V Twistlock
Weight	38.5 Kg

GENERATOR 6.5 HP

Optional wheel kit part# 85.400.029



Model#	BE-3100W
Engine	6.5 HP Honda GX200, Oil Alert
Max Output	3100 Watts
Continuous Output	2800 Watts
Voltage	120V/240V
Recepticles	120V Duplex, 240V Twistlock
Weight	41.3 Kg

GENERATOR 9 HP

Optional wheel kit part# 85.400.033



Model#	BE-4800W
Engine	9 HP Honda GX270, Oil Alert
Max Output	4800 Watts
Continuous Output	4500 Watts
Voltage	120V
Recepticles	120V Duplex, 120V Twistlock
Weight	60 Kg

GENERATOR 13 HP

Optional wheel kit part# 85.400.033



Model#	BE-7600W
Engine	13 HP Honda GX390, Oil Alert
Max Output	7600 Watts
Continuous Output	6500 Watts
Voltage	120V/240V
Recepticles	120V Duplex, 240V Twistlock
Weight	77 Kg



GENERAL PURPOSE WATER PUMPS

PACKAGING: Boxed

GENERAL PURPOSE WATER PUMP 1"



Model#	WP-1015HM
Size	1"
Engine	1.5 HP Honda GX31 4 Stroke
Pump	Centrifugal Aluminum
Max Flow	34 GPM
Total Head	96 ft.
Max Suction Head	25 ft.
Impeller	Aluminum
Solids	No Solids
Weight (dry)	14.3 lbs.

GENERAL PURPOSE WATER PUMP 2"

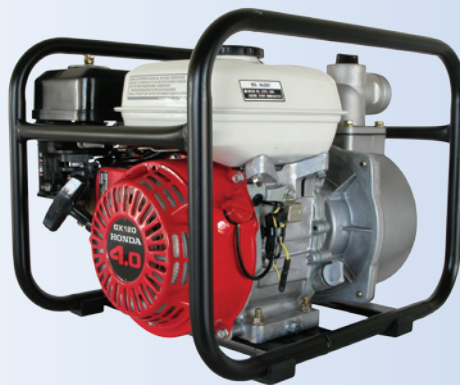

Model#	WP-2040HM
Size	2"
Engine	4.0 HP Honda GX120 Oil Alert
Pump	Centrifugal Aluminum
Max Flow	150 GPM
Total Head	105 ft.
Max Suction Head	26 ft.
Impeller	Cast Iron
Solids	No Solids
Weight (dry)	55 lbs.

GENERAL PURPOSE WATER PUMP 2"



Model#	WP-2050HM
Size	2"
Engine	5.0 HP Honda GC160
Pump	Centrifugal Aluminum
Max Flow	150 GPM
Total Head	105 ft.
Max Suction Head	26 ft.
Impeller	Cast Iron
Solids	No Solids
Weight (dry)	55 lbs.

GENERAL PURPOSE WATER PUMP 3"



Model#	WP-3050HM
Size	3"
Engine	5.5 HP Honda GX160 Oil Alert
Pump	Centrifugal Aluminum
Max Flow	265 GPM
Total Head	105 ft.
Max Suction Head	26 ft.
Impeller	Cast Iron
Solids	No Solids
Weight (dry)	65 lbs.



TRASH & HIGH PRESSURE PUMPS

PACKAGING: Boxed

TRASH PUMP 3"



Model#	TP-3080HM
Size	3"
Engine	8.0 HP GX Honda Oil Alert
Pump	Centrifugal Self Priming Alum.
Max Flow	286 GPM
Total Head	98 ft.
Max Suction Head	26 ft.
Impeller	Cast Iron
Solids	Yes
Weight (dry)	130 lbs.

TRASH PUMP 4"



Model#	TP-4011HM
Size	4"
Engine	11.0 HP GX Honda Oil Alert
Pump	Centrifugal Self Priming Alum.
Max Flow	506 GPM
Total Head	95 ft.
Max Suction Head	26 ft.
Impeller	Cast Iron
Solids	Yes
Weight (dry)	149 lbs.

HIGH PRESSURE TRANSFER PUMP

New high pressure system operates at 80 PSI, great for fire fighting and lawn sprinkling.



Model#	HP-2055HM
Size	2"
Engine	5.5 HP Honda GX160 Oil Alert
Pump	Centrifugal Aluminum
Max Flow	130 GPM
Total Head	165 ft.
Max Suction Head	26 ft.
Impeller	Cast Iron
Solids	No Solids
Weight (dry)	65 lbs.

HEAD DIAGRAM FOR ALL PUMPS

The following is a diagram to show how to set up a water pump or trash pump in relation to the water level, suction hose and discharge hose.

Pump head (pumping height) refers to the amount of lift (suction) and push (discharge) a pump is capable of. For best performance, place the pump as near to the water source as possible. This produces the greatest output with the least priming time. Since discharge head capability is always greater than suction head capability, it is important that suction head always be the shorter part of the total head. The following chart shows the water pump and trash pump capabilities.

Operation Tip: If the unit does not pump water right away, continue to add water through the priming plug until it is full.

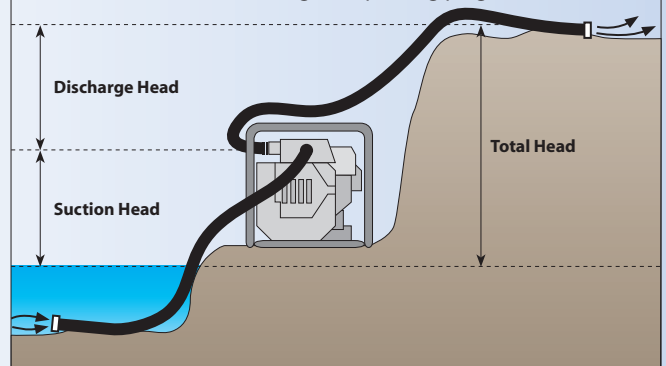



SEE PAGE 87 FOR MORE HOSE PRODUCTS

PACKAGING: Boxed

DISCHARGE HOSE KITS

Temperature Rating: 150° F



▼ Part#	Length	Size	Pressure	Weight
85.400.080	25 ft.	1"	80 PSI	10.5 lbs
85.400.081	25 ft.	2"	80 PSI	11.0 lbs
85.400.082	25 ft.	3"	65 PSI	11.5 lbs
85.400.083	25 ft.	4"	55 PSI	12.0 lbs
85.400.084	50 ft.	1"	80 PSI	21.0 lbs
85.400.085	50 ft.	2"	80 PSI	22.0 lbs
85.400.086	50 ft.	3"	65 PSI	23.0 lbs
85.400.087	50 ft.	4"	55 PSI	24.0 lbs

INDUSTRIAL DISCHARGE HOSE KITS

Temperature Rating: 150° F

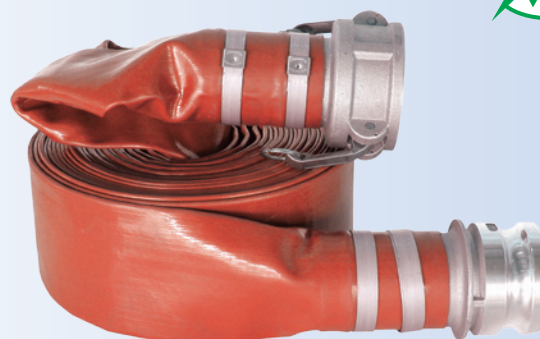

▼ Part#	Length	Size	Pressure	Weight
85.400.092	25 ft.	1"	150 PSI	11.0 lbs
85.400.093	25 ft.	2"	150 PSI	11.5 lbs
85.400.094	25 ft.	3"	150 PSI	12.0 lbs
85.400.095	25 ft.	4"	150 PSI	12.5 lbs
85.400.096	50 ft.	1"	150 PSI	22.0 lbs
85.400.097	50 ft.	2"	150 PSI	23.0 lbs
85.400.098	50 ft.	3"	150 PSI	24.0 lbs
85.400.099	50 ft.	4"	150 PSI	25.0 lbs

SUCTION HOSE KITS



▼ Part#	Length	Diameter	Weight
85.400.088	25 ft.	1"	5 lbs
85.400.089	25 ft.	2"	12 lbs
85.400.090	25 ft.	3"	16 lbs
85.400.091	25 ft.	4"	20 lbs

CAMLOCK FITTINGS

The camlock adapter threads onto the inlet and/or the outlet of the pump. The coupler hose barbs fit onto the hose, which can then be easily attached to the adapter. All camlocks are made of Aluminum.



▼ Part#	Size	Type	Weight
85.151.008	1"	A	1 lbs.
85.151.001	2"	A	1 lbs.
85.151.003	3"	A	2 lbs.
85.151.011	4"	A	2 lbs.



▼ Part#	Size	Type	Weight
85.151.009	1"	C	1 lbs.
85.151.002	2"	C	1 lbs.
85.151.004	3"	C	2 lbs.
85.151.012	4"	C	2 lbs.



▼ Part#	Size	Type	Weight
85.151.010	1"	E	1 lbs.
85.151.006	2"	E	1 lbs.
85.151.007	3"	E	2 lbs.
85.151.013	4"	E	2 lbs.



STAINLESS STEEL 4 WHEEL FRAME

PACKAGING: Boxed

A hydrostatic test unit allows the user to test line pressure on a system up to 580 PSI. The user is able to pump water into a closed pipeline system, set and lock the pressure, and test to see if there are any leaks in the pipeline system. Ideal for contractors or rental yards. This Hydrostatic unit provides easy use with a front facing control panel.

Pic Distinguishing Features

- A** Stainless steel frame and easy to use control panel
- B** Exclusive water gauge design [10 Gal tank]
- C** High capacity water filter

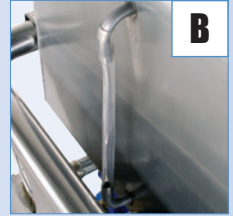

STAINLESS STEEL

HYDROSTATIC TESTING KIT

Can be used to convert any pressure washer into a hydrostatic line test unit.



Model#	85.400.004
Max Pressure	1,000 PSI
Max Temperature	140° F
Inlet Size	¾" GHT
Outlet Size	3/8" QC
Weight	5 lbs.

#	Model#	Engine	Pump	PSI	GPM	Diaphragms	Weight
1	HS-0655HWHY MODEL SHOWN	5.5 HP Honda GX160 (Oil Alert)	AR	580	9.3	2	210 lbs

Pic	Feature	Pic	Feature	Pic	Feature
	• Honda 5.5 HP GX160 Gas Engine	3	AR Diaphragm Pump	5	Easy Read Control Panel
1	13" Tubed Pneumatic Tires	4	Stainless Steel 10 Gallon Water Reservoir Tank		
2	5" Oversize Inlet Water Filter				





STAINLESS STEEL 2 WHEEL FRAME

PACKAGING: Boxed

A hydrostatic test unit allows the user to test line pressure on a system up to 580 PSI. The user is able to pump water into a closed pipeline system, set and lock the pressure, and test to see if there are any leaks in the pipeline system. Ideal for contractors or rental yards. This hydrostatic unit is compact and provides easy portability.

STAINLESS STEEL

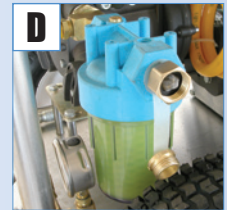
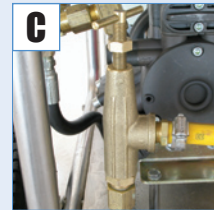
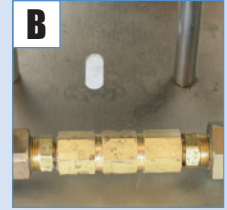
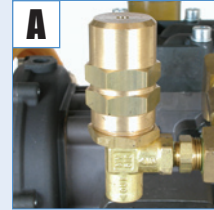

Pic	Distinguishing Features
A	Safety Relief Valve
B	1 Way Check Valve for Line Pressure
C	Pressure Regulator
D	5" Oversized Inlet Water Filter



#	Model#	Engine	Pump	PSI	GPM	Diaphragms	Weight
2	HS-0650HWHY MODEL SHOWN	Honda 5.5 HP GX160 (Oil Alert)	Comet APS31	580	6.6	3	190 lbs

Pic	Feature	Pic	Feature	Pic	Feature
1	Honda 5.5 HP GX160 Gas Engine	2	5" Oversize Inlet Water Filter	4	Stainless Steel 15 Gallon Water Reservoir Tank
1	13" Tubed Pneumatic Tires	3	Comet Diaphragm Pump		





STAINLESS STEEL FRAME

PACKAGING: Boxed

Pic	Distinguishing Features
A	Frame Mounted Hose Reel
B	All Stainless Steel Frame
C	Panel Mounted Pressure Gauge

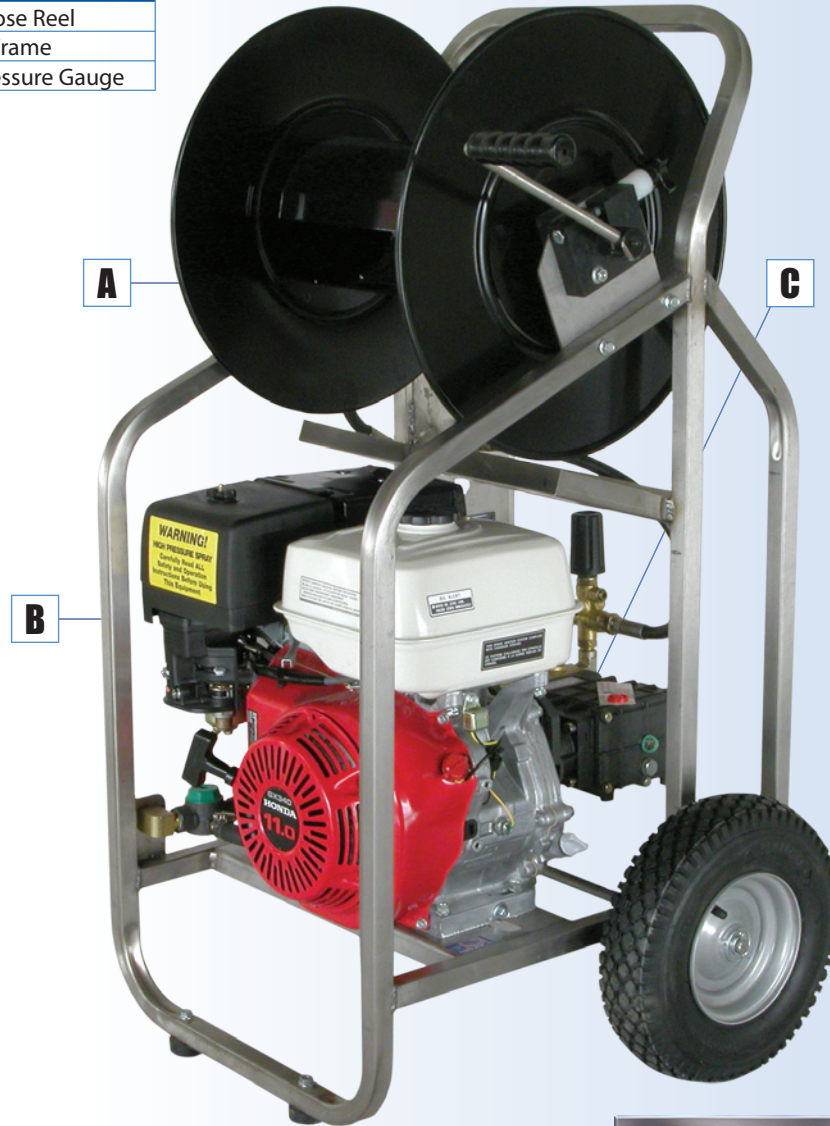

STAINLESS STEEL

Model#	Engine	PSI	GPM	Sewer Hose	Nozzle Set	Hose Reel	Pulse	Weight
BE215EJ	1.5 HP (1 phase)	1,500	2.0	1/4-150' 1/8-50'	2-1/8" 2-1/4"	50' (removable)	Constant	160 lbs
BE325GJ	6.5 HP Honda	2,000	3.5	1/4-150' 1/8-50'	2-1/8" 2-1/4"	50' (removable)	Variable	160 lbs
BE430GJ	11 HP Honda	3,000	4.0	3/8-200' 1/4-100'	4 piece set	400'	Variable	190 lbs
BE4530GJ MODEL SHOWN	13 HP Honda	3,000	4.0	200' 3/8"	*See Below	400'	Variable	190 lbs
	Nozzles			Part#	Description			
	Laser			33-104242	Holes forward and backward			
	Laser			33-104206	Holes forward and backward			
	RAM			33-104218	Hole backwards only			
	RAM			33-104230	Hole backwards only			
BE830GJB	24 HP Honda	3,000	8.0	Ordered seperate	Ordered seperate	Sludge Buddy	Variable	290 lbs



HOT WATER TOWERS, SKID AND TIRE MOUNTED

PACKAGING: Boxed

HOT WATER TOWERS (TIRE MOUNT DIESEL)

Call for custom hot washer designs.



Model#	HT-2003D
Max Pressure	2,000 PSI
Max Flow	3 GPM
Voltage	110V AC, 15A
Switch	Flow
Fuel Nozzle	1.50-1.65
Weight	340 lbs

HOT WATER TOWERS (TIRE MOUNT DIESEL)

Call for custom hot washer designs.



Model#	HT-3004D
Max Pressure	3,000 PSI
Max Flow	4 GPM
Voltage	110V AC, 15A
Switch	Flow
Fuel Nozzle	2.0
Weight	390 lbs

HOT WATER TOWERS (TIRE MOUNT DIESEL)

For 9.0-13 HP (18A Charger) Honda Engine. Call for custom hot washer designs.

Model#	85.380.001L
Max Pressure	3,500 - 4,000 PSI
Max Flow	4.0 GPM
Voltage	12V DC
Switch	Pressure
Fuel Nozzle	2.0
Weight	390 lbs

HOT WATER TOWERS (SKID MOUNT DIESEL)

Units do not come with pump, engine, or battery. Call for a custom quotation. Specifications may vary with elevation and inlet water temperature (average water temperature is 50° F). Units that will be started and stopped frequently should use a pull start engine instead of an electric start engine. Use 9.0-25.0 HP (18A charger) Honda engines.

Model#	85.380.003
Max Pressure	4,000 PSI
Max Flow	4.6-5.6 GPM
Voltage	12V DC
Switch	Pressure
Fuel Nozzle	2.50-2.75
Weight	425 lbs



BE 



SECTION 2

SPECIALTY CLEANING UNITS

WATER BROOMS

Large Water Broom	48
Small Water Broom	48
Ball Valve Kit	48

FLAT SURFACE CLEANERS

POLYPROPYLENE

16" Whirl-A-Way	49
18" Whirl-A-Way	50
20" Whirl-A-Way	51

STAINLESS STEEL

20" Whirl-A-Way	52
24" Whirl-A-Way	53

TELESCOPING WANDS

Fiberglass	54
Aluminum	56
Paint Poles and Accessories	57

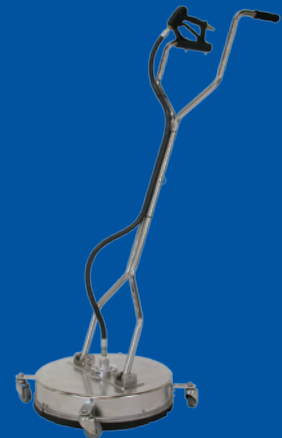

DRIVEWAY, BEFORE

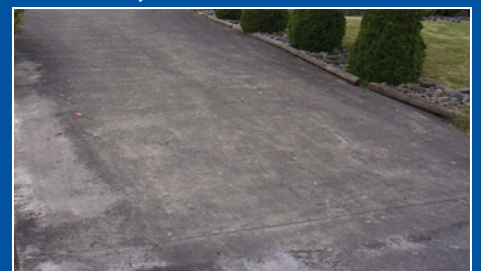

DRIVEWAY, AFTER





PACKAGING: Boxed

WATER BROOM, SMALL

Used for cleaning vast surfaces quickly.



Spray action of the Water Broom



Part#	85.400.060
Max Pressure	4,000 PSI
Max Flow	3 GPM
Width	12"
Connection	1/4" Quick-Disconnect plug
Nozzles	3
Replacement Nozzles	85.265.013
Weight	3.5 lbs

WATER BROOM, LARGE

Used for cleaning vast surfaces quickly.

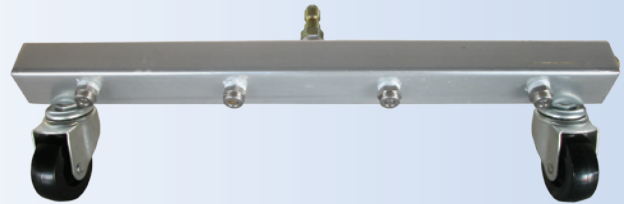

Spray action of the Water Broom



Part#	85.400.061
Max Pressure	4,000 PSI
Max Flow	5-6 GPM
Width	16"
Connection	1/4" Quick-Disconnect plug
Nozzles	4
Replacement Nozzles	85.265.013
Weight	4.5 lbs

BALL VALVE KIT

Allows you to switch between Whirl-A-Way and Wand without having to shutdown the unit.

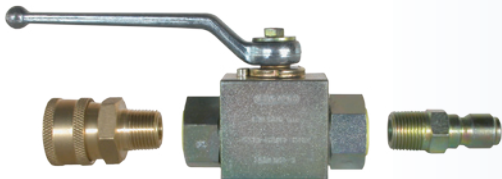

Part#	85.300.044
Weight	1.4 lbs

COMPONENTS	Part#
3/8" QD Coupler, 3/8" MNPT	85.300.108
Ball Valve, 3/8" FNPT	85.300.046
3/8" QD Plug, 3/8" MNPT	85.300.105



16" WHIRL-A-WAY, HEAVY DUTY COMPOSITE

PACKAGING: Boxed

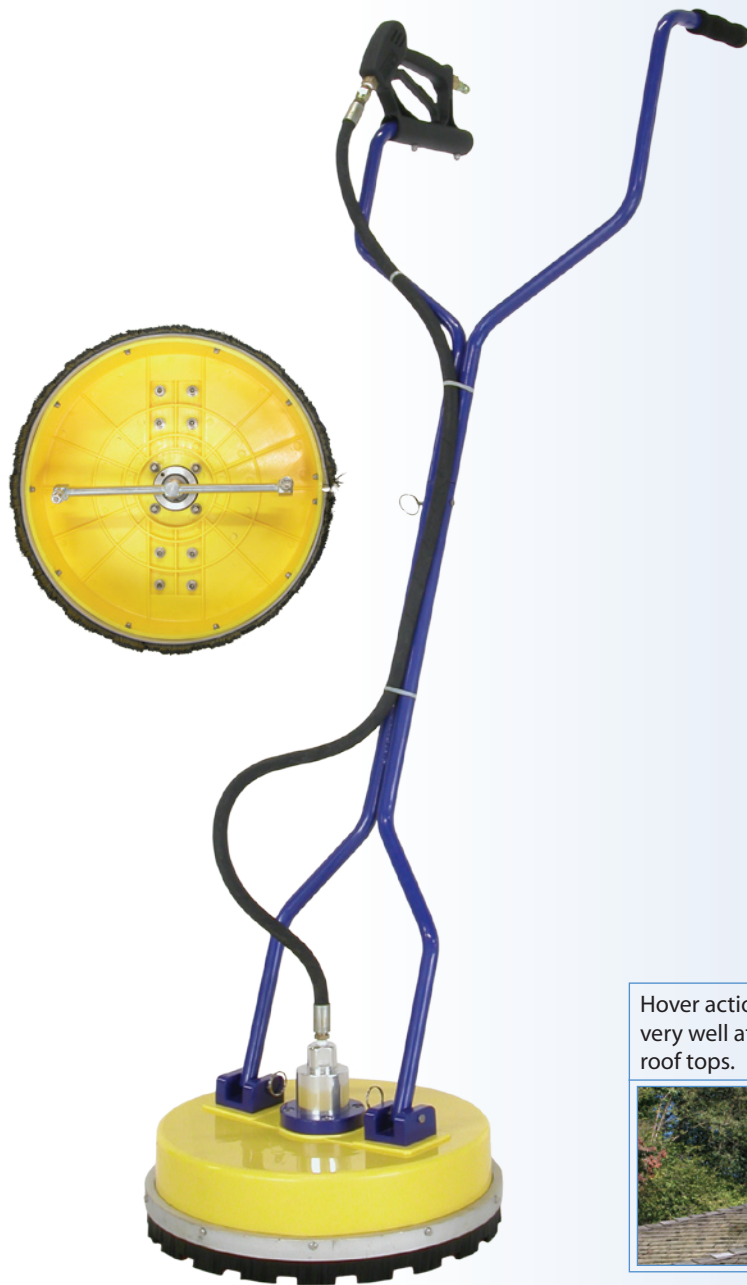

The following comparison chart shows the time taken to clean a typical size driveway (400 sq. ft.) using 3 different components.

Unit	Time to clean
▶ Whirl-A-Way	10 Minutes
Water Broom	30 Minutes
Spray Nozzle	80 Minutes

Whirl-A-Way Rotary Head Breakdown

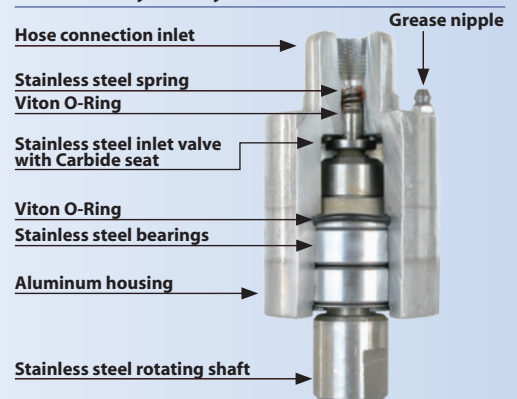

Part# Optional Kits

85.300.044 Ball Valve Kit
Allows you to switch between Whirl-A-Way and Wand without having to shutdown the unit.



Hover action works very well at cleaning roof tops.



Part# Replacement Part

85.790.004	Rotary Head
85.791.009	Rotary Arm
85.790.010	Rotary Head Repair Kit
85.225.025	Replacement Nozzle Tip
85.790.012	Nylon Brush Skirt
85.202.017	Replacement Spray Gun

#	Model#	Max Pressure	Max Flow	Max Temp.	Size	Weight
1	BE-1600WAW	4,000 PSI	8.0 GPM	160°F	16" diameter	26 lbs.

Pic	Feature	Pic	Feature
1	Durable Nylon Brush Skirt	5	Welded Elbows and Assembly
2	Heavy Duty Polypropylene Cover	6	Field Repairable Gun
3	4,000 PSI Rotary Head, 160°F		• Water Flow Out Front Prevents Cavitation
4	Welded Steel Rotary Arm		• Zero Wall Clearance

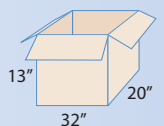



18" WHIRL-A-WAY, HEAVY DUTY COMPOSITE

PACKAGING: Boxed

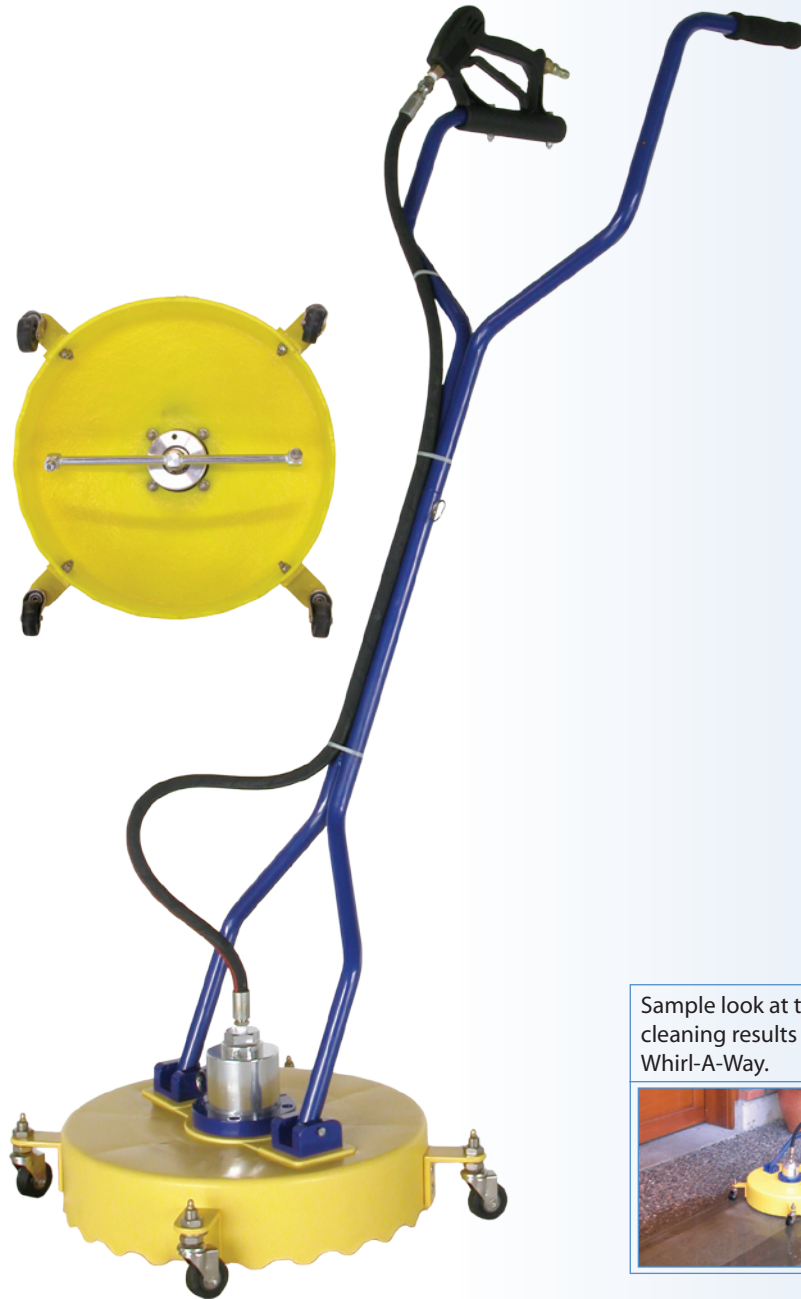

The following comparison chart shows the time taken to clean a typical size driveway (400 sq. ft.) using 3 different components.

Unit	Time to clean
▶ Whirl-A-Way	10 Minutes
Water Broom	30 Minutes
Spray Nozzle	80 Minutes

Whirl-A-Way Rotary Head Breakdown

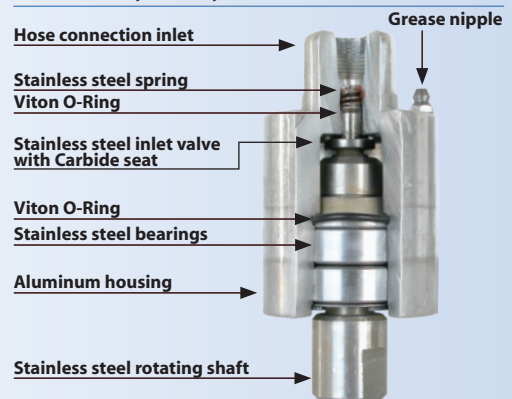

Part# Optional Kits

85.300.044 Ball Valve Kit

Allows you to switch between Whirl-A-Way and Wand without having to shutdown the unit.

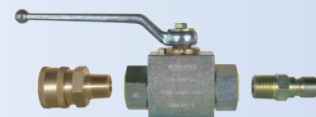

Sample look at the cleaning results of a Whirl-A-Way.



Part# Replacement Part

85.790.006 Rotary Head
85.791.007 Rotary Arm
85.790.010 Rotary Head Repair Kit
85.225.025 Replacement Nozzle Tip
85.790.007 1" Caster Wheels
85.202.115 Replacement Spray Gun

#	Model#	Max Pressure	Max Flow	Max Temp.	Size	Weight
1	BE-1800AW MODEL SHOWN	4,000 PSI	8.0 GPM	160°F	18" diameter	32 lbs.

Pic	Feature	Pic	Feature
1	Greasable Casters	5	Welded Elbows and Assembly
2	Heavy Duty Polypropylene Cover	6	Field Repairable Gun
3	4,000 PSI Rotary Head, 160°F		• Water Flow Out Front Prevents Cavitation
4	Welded Steel Rotary Arm		• Zero Wall Clearance

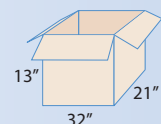
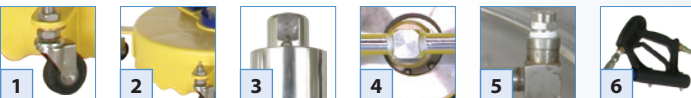



20" WHIRL-A-WAY, HEAVY DUTY COMPOSITE

PACKAGING: Boxed



The following comparison chart shows the time taken to clean a typical size driveway (400 sq. ft.) using 3 different components.

Unit	Time to clean
▶ Whirl-A-Way	10 Minutes
Water Broom	30 Minutes
Spray Nozzle	80 Minutes

Whirl-A-Way Rotary Head Breakdown

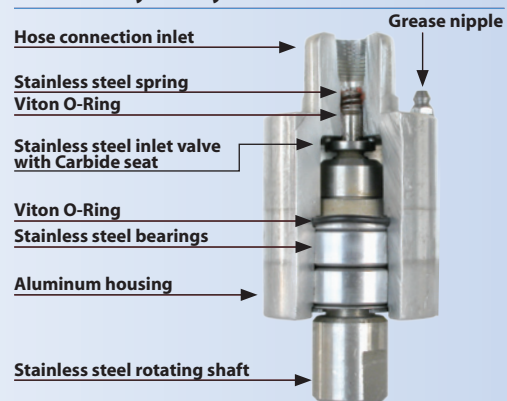

Part#	Optional Kits
85.300.044	Ball Valve Kit

Allows you to switch between Whirl-A-Way and Wand without having to shutdown the unit.



Hover action works very well at cleaning roof tops.



Part#	Replacement Part
85.790.004	Rotary Head
85.791.013	Rotary Arm
85.790.010	Rotary Head Repair Kit
85.225.025	Replacement Nozzle Tip
85.790.014	Nylon Brush Skirt
85.202.115	Replacement Spray Gun

#	Model#	Max Pressure	Max Flow	Max Temp.	Size	Weight
1	BE-2000WAWY MODEL SHOWN	4,000 PSI	8.0 GPM	160°F	20" diameter	32 lbs.

Pic	Feature	Pic	Feature
1	Durable Nylon Brush Skirt	5	Welded Elbows and Assembly
2	Heavy Duty Polypropylene Cover	6	Field Repairable Gun
3	4,000 PSI Rotary Head, 160°F		• Water Flow Out Front Prevents Cavitation
4	Welded Steel Rotary Arm		• Zero Wall Clearance

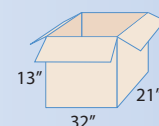



20" WHIRL-A-WAY, STAINLESS STEEL

PACKAGING: Boxed

STAINLESS STEEL

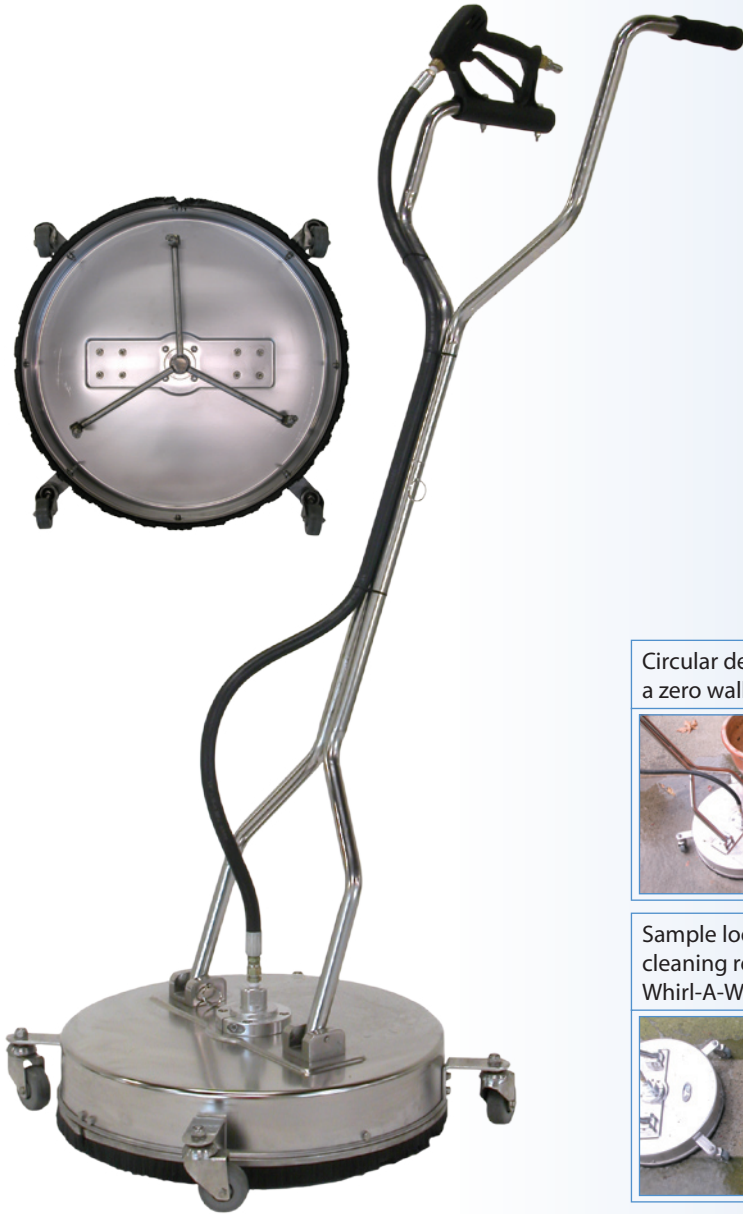

Circular design allows a zero wall clearance.



Sample look at the cleaning results of a Whirl-A-Way.



The following comparison chart shows the time taken to clean a typical size driveway (400 sq. ft.) using 3 different components.

Unit	Time to clean
▶ Whirl-A-Way	10 Minutes
Water Broom	30 Minutes
Spray Nozzle	80 Minutes

Whirl-A-Way Rotary Head Breakdown

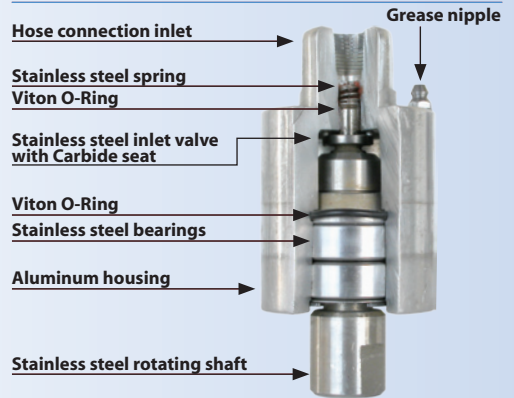

Part#	Optional Kits
85.300.044	Ball Valve Kit
Allows you to switch between Whirl-A-Way and Wand without having to shutdown the unit.	



Part#	Replacement Part
85.790.004	Rotary Head
85.791.012	Tri-Rotary Arm
85.790.009	1" Non Marking Caster
85.790.014S	Nylon Brush Skirt
85.790.010	Rotary Head Repair Kit
85.225.020	Replacement Nozzle Tip
85.202.115	Replacement Spray Gun

#	Model#	Max Pressure	Max Flow	Max Temp.	Size	Weight
1	BE-2000WAWs MODEL SHOWN	4,000 PSI	8.0 GPM	180°F	20" diameter	38 lbs.

Pic	Feature	Pic	Feature
1	Non Marking Casters	5	Welded Elbows and Assembly
2	Stainless Steel Bearings	6	Field Repairable Gun
3	4,000 PSI Rotary Head, 160°F		• Water Flow Out Front Prevents Cavitation
4	Welded Stainless Steel Rotary Arm		• Zero Wall Clearance

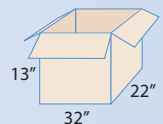
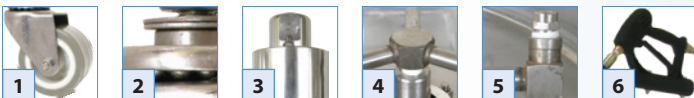



24" WHIRL-A-WAY, STAINLESS STEEL

PACKAGING: Boxed

STAINLESS STEEL

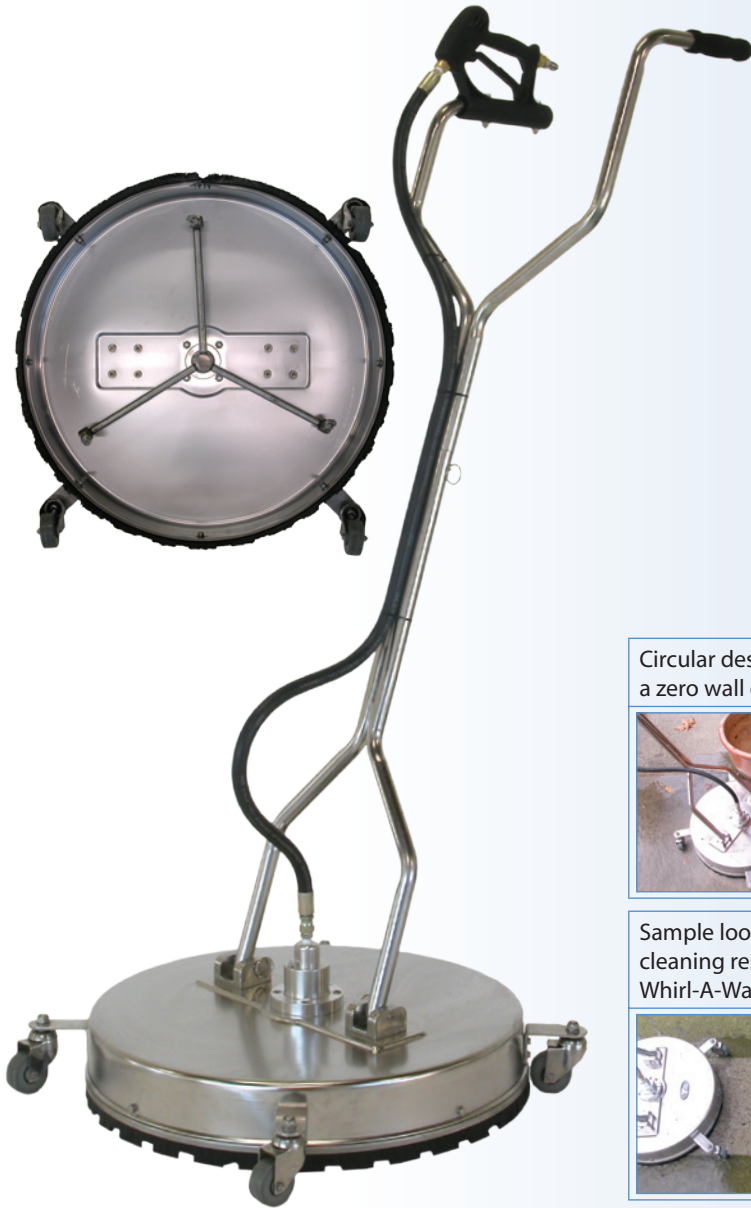

Circular design allows a zero wall clearance.



Sample look at the cleaning results of a Whirl-A-Way.



The following comparison chart shows the time taken to clean a typical size driveway (400 sq. ft.) using 3 different components.

Unit	Time to clean
▶ Whirl-A-Way	10 Minutes
Water Broom	30 Minutes
Spray Nozzle	80 Minutes

Whirl-A-Way Rotary Head Breakdown

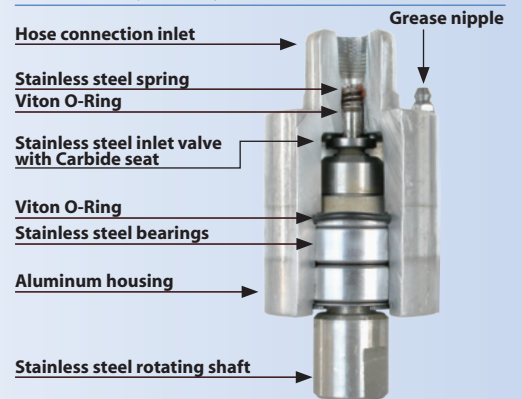

Part#	Optional Kits
85.300.044	Ball Valve Kit

Allows you to switch between Whirl-A-Way and Wand without having to shutdown the unit.



Part#	Replacement Part
85.790.004	Rotary Head
85.791.010S	Tri-Rotary Arm 11"r
85.790.020	1.5" Non Marking Caster
85.790.019S	Nylon Bursh Skirt
85.790.010	Rotary Head Repair Kit
85.225.020	Replacement Nozzle Tip
85.202.115	Replacement Spray Gun

#	Model#	Max Pressure	Max Flow	Max Temp.	Size	Weight
1	BE-2400WAWS MODEL SHOWN	4,000 PSI	8.0 GPM	160°F	24" diameter	45 lbs.

Pic	Feature	Pic	Feature
1	Non Marking Casters	5	Welded Elbows and Assembly
2	Stainless Steel Bearings	6	Field Repairable Gun
3	4,000 PSI Rotary Head, 160°F		• Water Flow Out Front Prevents Cavitation
4	Welded Stainless Steel Rotary Arm		• Zero Wall Clearance

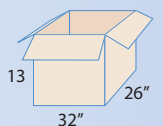



FIBERGLASS, SUPER HEAVY DUTY

PACKAGING: Boxed

Used to reach high places. Telescoping wand will reach a height of 9 to 24 feet.

Features

- ▶ Two fiberglass outer poles and one aluminum inner pole.
- ▶ **Light weight fiberglass wand**

Telescoping wand being used to clean a roof top



Part# Replacement Parts

85.205.104	Pole Lock
85.205.105	Pole Lock
85.202.113	Spray Gun

Screw-Type Coarse Super Grip locking Devices



Super-Flex Zylon Gun



Belt Kit Included



Part#	Optional Kits
85.400.008	Rotating Brush



Part#	Optional Kits
85.400.007	Gutter Cleaner



#	Model#	Max Pressure	Max Flow	Max Temp.	Length	Hose	Weight
1	85.205.024SHD MODEL SHOWN	4,000 PSI	8 GPM	200°F	9ft. ▶ 24ft.	1/4"	16 lbs



FIBERGLASS, HEAVY DUTY

PACKAGING: Boxed



Used to reach high places. Telescoping wand will reach a height of 6 to 24 feet.

Features

- ▶ Thread-in spraying gun mechanism
- ▶ Two aluminum poles and fiberglass outer pole.
- ▶ **Light weight fiberglass wand**

Screw-type locking devices



Thread-in spraying gun mechanism

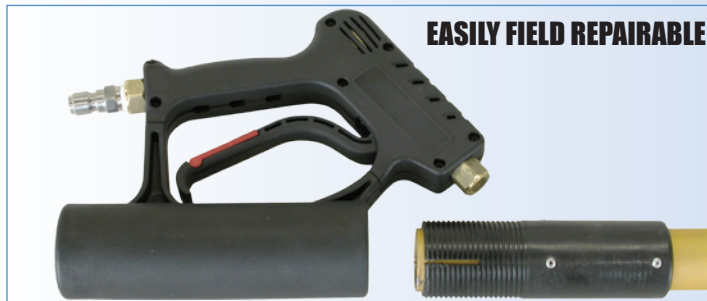

Gutter cleaner attachment



Part# **Optional Kits**
85.400.019 Belt Kit



Part# **Optional Kits**
85.400.033 Gutter Cleaner Kit



Part# **Optional Kits**
85.400.008 Rotating Brush



#	Model#		Max Pressure	Max Flow	Max Temp.	Length	Hose	Weight
2	85.206.012	MODEL SHOWN	4,000 PSI	8 GPM	200°F	6ft. 6" ▶ 12ft.	1/4"	7.5 lbs
3	85.206.018		4,000 PSI	8 GPM	200°F	6ft. 6" ▶ 18ft.	1/4"	8.5 lbs
4	85.206.024		4,000 PSI	8 GPM	200°F	9ft. ▶ 24ft.	1/4"	10.5 lbs



ALUMINUM, SUPER HEAVY DUTY

PACKAGING: Boxed



The new standard in Industrial Telescoping Wands.

Features

- ▶ Thread-in spraying gun mechanism
- ▶ Stainless steel end pole, tight crimped and reinforced by set screws
- ▶ Two side flat aluminum poles for easy retracting and non-spining during operation.
- ▶ **Light weight aluminum wand**

Easy Pin-Lock Couplers



Screw-Type Connect



Thread-in spraying gun mechanism



EASILY FIELD REPAIRABLE

Telescoping wand cleaning high walls

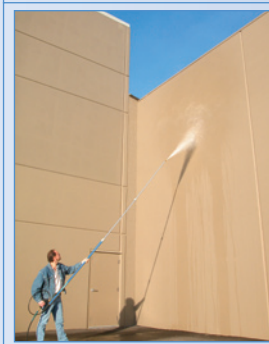

Belt Kit Included



Part#	Optional Kits
85.400.033	Gutter Cleaner Kit



Part#	Optional Kits
85.400.008	Rotating Brush

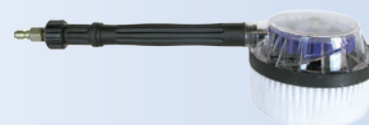

#	Model#	Max Pressure	Max Flow	Max Temp.	Length	Hose	Weight
7	85.205.018ALSHD MODEL SHOWN	3,000 PSI	8 GPM	200°F	6ft. 6" ▶ 18ft.	1/4"	13 lbs
8	85.205.024ALSHD	3,000 PSI	8 GPM	200°F	9ft. ▶ 24ft.	1/4"	16.5 lbs



PACKAGING: Boxed

GUTTER CLEANER

Turns wands into efficient gutter cleaners so that gutters can be cleaned from the ground.



Part#	85.400.007
Max Pressure	3,000 PSI
Outlet	1/4" quick connect
Inlet	1/4" plug
Weight	0.55 lbs

GUTTER CLEANER KIT

This gutter pole attaches to the new style BE Long Wand. Held firmly in place by an M22 Fitting.



Part#	85.400.033
Max Pressure	3,000 PSI
Outlet	40°, #40 Spray Tip (1/4" FNPT)
Inlet	M22 Male
Weight	0.55 lbs

NYLON BRUSH, ROTATING

Attach to telescoping wand to provide low pressure scrubbing action.



Part#	85.400.008
Max Pressure	2,000 PSI
Max Temperature	140° F
Inlet	1/4" quick connect plug
Weight	1.15 lbs

PAINT POLE

With foam grip handle.

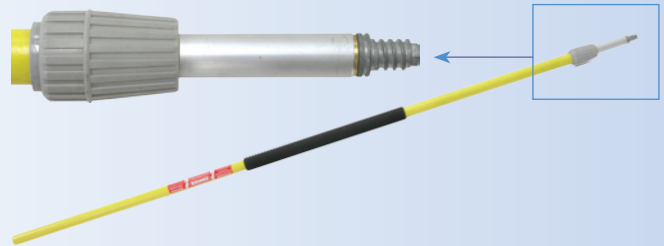

Part#	Length
85.205.212	6ft. 6" ▶ 12ft.
85.205.218	6ft. 6" ▶ 18ft.
85.205.224	8ft. 6" ▶ 24ft.

TELESCOPING WAND, BELT KIT

Used to support Long Wands, taking stress off the arms and body. For use with all Long Wands. Fits any size (adjustable).

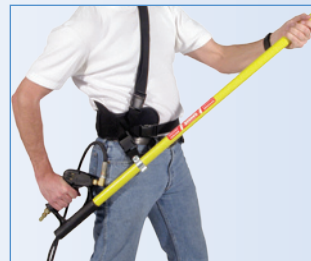

Part#	Telescoping Wands
85.400.019	Fits all BE Long Wands



SECTION 3

MATERIAL HANDLING GOODS

MATERIAL HANDLING GOODS

Dolleys and Trolleys	60
Hand Carts and Hydraulics	61
Utility and Tool Carts	62
Jacks	63
Trailer Jacks	64





PACKAGING: Boxed

SMALL TRUCK DOLLY



Part# 85.600.011

Capacity	600 lbs
Wheels	11" Pneumatic Tires
Height	52"
Frame	Red Powder Coated
Handle	Loop For Easy Use
Weight	27 lbs

LARGE TRUCK DOLLY



Part# 85.600.012

Capacity	700 lbs
Wheels	14" Pneumatic Tires
Height	52"
Frame	Red Powder Coated
Handle	Loop For Easy Use
Weight	31 lbs.

APPLIANCE DOLLY



Part# 85.600.014

Capacity	750 lbs
Wheels	6" Solid Rubber Tires
Height	60½"
Frame	Red Powder Coated
Treads	Crawler For Stairs
Rubber	Non Marking
Ratchet	Secure & Tighten Load
Weight	48 lbs

HAND TROLLEY



Part# HT1842

Capacity	550 lbs
Wheels	10" Pneumatic Tires
Body Size	L52" x W22" x H18"
Toe Plate Width	7"
Frame	Red Powder Coated
Weight	30 lbs.



PACKAGING: Boxed

PLATFORM HAND TRUCK



Part#	PH150
Capacity	150 Kgs
Wheels	2" casters
Body Size	L28" x W18"
Weight	20 lbs

PLATFORM HAND TRUCK



Part#	PH300
Capacity	300 Kgs
Wheels	5" casters
Body Size	L35" x 24"W
Weight	37 lbs

MOVING CART



Part#	D1000
Capacity	600 lbs
Wheels	3" casters
Body Size	L30" x W18" x H5.5"
Weight	12 lbs

PALLET JACK



Part#	PJ5500R
Capacity	5,500 lbs
Front Wheels	2 Rubber Wheels
Fork Wheels	Polyurethane 2" x 7"
Outside Fork	27"
Inside Fork	15"
Fork Length	48"
Handle	3 Control Position
Weight	203 lbs

HYDRAULIC LIFT



Part#	85.600.200
Capacity	300 Kgs.
Wheels	5" casters
Base Plate	L32" x W20"
Weight	160 lbs



PACKAGING: Boxed

TOOL CART, SOLID BASE

Part#	TC1820
Capacity	250 lbs
Wheels	10" Pneumatic Tires
Body Size	L42" x W20" x H13"
Frame	Gray Powder Coated
Weight	64 lbs

UTILITY CART, OPEN DECK

Part#	TC1807
Capacity	250 lbs
Wheels	10" Pneumatic Tires
Body Size	L48" x W24" x H12"
Frame	Green Powder Coated
Weight	58 lbs

GARDEN CART

Part#	TC1858
Capacity	250 lbs
Wheels	13" Pneumatic Tires
Body Size	L52" x W30" x H40"
Frame	Green Plastic
Weight	80 lbs

ACCESSORY CART

Part#	85.600.010
Wheels	4" Lockable Casters
Height	34¼"
Frame	Red Powder Coated
Trays	L29" x W15¼" x H2"
Weight	31 lbs

ACCESSORY CART, TOOL CHEST

Part#	85.600.201
Wheels	4" Lockable Casters
Height	34¼"
Frame	Red Powder Coated
Trays	L29" x W15¼" x H3"
Drawers	2
Weight	74 lbs



PACKAGING: Boxed

SIDE WIND JACK



Part#	BE-050	BE-550
Capacity	5,000 lbs	5,000 lbs
Wind	Side	Side
Lift	10"	15"
Length	11¼"	15½"
Weight	13 lbs	15 lbs

SIDE WIND JACK (PREMIUM)



Part#	LT-5103	LT-5153
Capacity	5,000 lbs	5,000 lbs
Wind	Side	Side
Lift	10"	15"
Length	11¼"	15½"
Weight	13.5 lbs	15 lbs

TOP WIND JACK



Part#	BE-020	BE-520
Capacity	2,000 lbs	2,000 lbs
Wind	Top	Top
Lift	10"	15"
Length	11¼"	15½"
Weight	11 lbs	13.5 lbs

TOP WIND JACK (PREMIUM)



Part#	ST-2104	ST-2154
Capacity	2,000 lbs	2,000 lbs
Wind	Top	Top
Lift	10"	15"
Length	11¼"	15½"
Weight	10.5 lbs	12.5 lbs

TOP WIND JACK

Bracket & retaining ring swivel mount. Locks in 4 positions. Includes mounting plate, retaining ring, spring loaded lock pin and grease nipple.



Part#	FJ-020
Capacity	2,000 lbs
Wind	Top
Lift	10"
Length	11"
Weight	11 lbs

TOP WIND JACK

Bracket & retaining ring swivel mount. Locks in 4 positions. Includes mounting plate, retaining ring, spring loaded lock pin and grease nipple.



Part#	FJ-530
Capacity	2,000 lbs
Wind	Side
Lift	15"
Length	15"
Weight	14 lbs



PACKAGING: Boxed

TRAILER JACK, SMALL

Comes with grease nipple

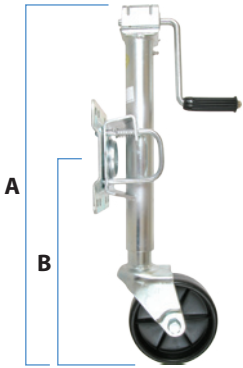

Part#	TJ-06-01K
Capacity	1,000 lbs
Lift	10"
Retracted Height (A)	24"
Retracted Mount H. (B)	14"

TRAILER JACK, MEDIUM

Comes with grease nipple

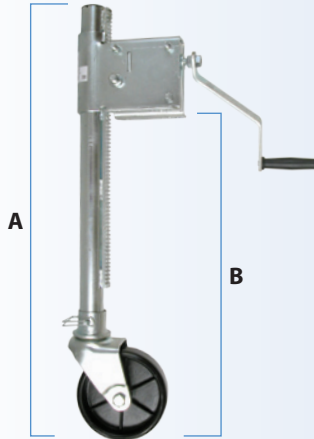

Part#	TJ-06-405
Capacity	750 lbs
Lift	14"
Retracted Height (A)	29"
Retracted Mount H. (B)	8.5" - 23"

TRAILER JACK, LARGE

Comes with grease nipple

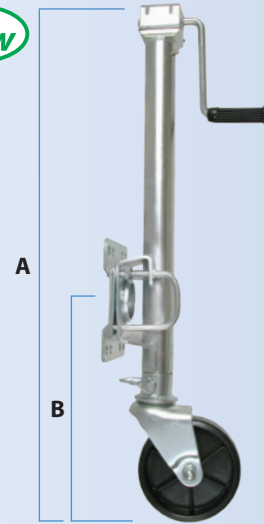

Part#	TJ-06-51L
Capacity	1,000 lbs
Lift	15"
Retracted Height (A)	30"
Retracted Mount H. (B)	12.5"

BE 



SECTION 4

HIGH PRESSURE PUMPS

CAT PUMPS

2DX, 3DX	68
2SF	68
66DX	68
5CP	68

COMET PUMPS

AXD	69
GXD	69
LWD	69
ZWD	70
FW/HWS	70
TW	70

GENERAL PUMPS

TP	71
TZ/TX	71
T	71
TS	71

PUMP KITS

Cat Pump, Seal & Valve Kits	72
General Pump, Kits	72
Comet Pump, Seal & Valve Kits	73
Replacement Oil Caps	73





BARE PUMPS AVAILABLE ON REQUEST.

PACKAGING: Boxed

2DX, 3DX SERIES



Triplex plunger design provides smooth liquid flow. Formulated high pressure seals and ground ceramic plungers assure maximum seal life. Compact design for maximum portability. Built-in modular regulating unloader and bypass to assure system pressure control and pump protection.



▼ Part#	Model	GPM	PSI	HP	RPM	Shaft	Motor
85.119.019B	2DX20E	2.0	2,000	1.5-2	3,450	5/8"	Elec.
85.119.018B	2DX27GS	2.7	2,000	5.5	3,450	3/4"	Gas
85.119.028B	3DX25GS1	2.5	2,500	6.5	3,450	3/4"	Gas

Model	Seal Kit	Valve Kit	Oil Cap	Unloader	Piston
2DX20E	33053	33057	45690	33099 Orings	542403
2DX27GS	33053	33057	45690	33099 Orings	542403
3DX25GS1	30530	33057	45690	33099 Orings	542403

2SF SERIES



Triplex design with spring loaded inlet valves and flow through ceramic plungers provides smooth steady flow. Uniflow design provides continuous liquid flow forward through pump, reduces cavitation.



▼ Part#	Model	GPM	PSI	HP	RPM	Shaft	Motor
85.119.012B	2SF22ES	2.0	2,000	3	3,450	5/8"	Elec.
85.119.002B	2SFX30GS	3.0	2,000	5.5	3,450	3/4"	Gas

Model	Seal Kit	Valve Kit	Oil Cap	Unloader	Piston
2SF22ES	34053	34052	45690	32097 Orings	45847
2SFX30GS	34053	34056	45690	32097 Orings	45847

66DX SERIES



Triplex plunger design provides smooth liquid flow. Formulated high pressure seals and ground ceramic plungers assure maximum seal life.



▼ Part#	Model	GPM	PSI	HP	RPM	Shaft	Motor
85.119.014B	66DX40GG1	4.0	3,000	11	3,300	1"	Gas
85.119.025B	66DX35GG1	3.5	4,000	13	3,400	1"	Gas

Model	Seal Kit	Valve Kit	Oil Cap	Unloader	Piston
66DX40GG1	34262	34260 (2)	46798	85.300.006	48752
66DX35GG1	34262	34260 (2)	46798	85.300.007	48752

5CP SERIES



Triplex plunger design gives smooth liquid flow. Large oil bath crankcase assures optimum lubrication. Ground ceramic plungers assure maximum seal life. Oversized crankshaft bearings with greater load capacity creating longer bearing life.



▼ Part#	Model	GPM	PSI	HP	RPM	Shaft	Motor
85.119.021B	5CP3120	4.5	3/3,500	11/13	1,645	20mm	Gas

Model	Seal Kit	Valve Kit	Oil Cap	Unloader	Piston
5CP3120	33629	33060 (2)	46798	85.300.012	46884



BARE PUMPS AVAILABLE ON REQUEST.

PACKAGING: Boxed

AXD SERIES



The cadillac of axial radial pumps, the AXD has built a reputation as the most durable pump in its class. With stainless steel check valves and heat resistant plungers it will withstand the test of time.



▼ Part#	Model	GPM	PSI	HP	RPM	Shaft	Motor
85.149.023B	AXD2518G	2.5	1,800	4	3,400	3/4"	Gas
85.149.049B	AXD2325G	2.5	2,300	5	3,400	3/4"	Gas
85.149.026B	AXD2527G	2.5	2,700	6.5	3,400	3/4"	Gas
85.149.035B	AXD3030G	3.0	3,000	9	3,400	3/4"	Gas
85.149.037B	AXD3530G	3.5	3,000	11	3,400	3/4"	Gas
85.149.036B	AXD4030G	4.0	3,000	11	3,400	3/4"	Gas
85.149.024B	AXD2020E	2.0	2,000	1.5-2	3,400	5/8"	Elec.
85.149.025B	AXD3020E	3.0	2,000	3	3,400	5/8"	Elec.

Model	Seal Kit	Valve Kit	Oil Cap	Unloader
AXD2518G	5019007700	5025001400	3200007100	1215027100
AXD2325G	5019007800	5025001400	3200007100	1215027100
AXD2527G	5019007800	5025001400	3200007100	1215027100
AXD3030G	5019008600	5025001400	3200007100	1215027100
AXD3530G	5019008600	5025001400	3200007100	1215027100
AXD4030G	5019008600	5025001400	3200007100	1215027100
AXD2020E	5019007700	5025001400	3200007100	1215027100
AXD3020E	5019007700	5025001400	3200007100	1215027100

GXD SERIES



The newest member to the Comet family, GXD offers a more economic point to its big brother AXD while still sharing most of the same features.



▼ Part#	Model	GPM	PSI	HP	RPM	Shaft	Motor
85.149.060B	GXD2523G	2.5	2,300	5	3,400	3/4"	Gas
85.149.061B	GXD2527G	2.5	2,700	6.5	3,400	3/4"	Gas

Model	Seal Kit	Valve Kit	Unloader
GXD2523G	5026025600	5025001400	1215027100
GXD2527G	5026025600	5025001400	1215027100

LWD SERIES



Over built for its class with oversized ball bearings and forged brass connecting rods with a lifetime warranty. Optimal oil bath makes working at high speed look too easy.



▼ Part#	Model	GPM	PSI	HP	RPM	Shaft	Motor
85.149.021B	LWDK2020E	2.2	2,000	1.5-3	3,400	5/8"	Elec.
85.149.009B	LWDK3020G	3.0	2,000	5.5	3,400	3/4"	Gas
85.149.015B	LWDK3025G	3.0	2,500	6.5	3,400	3/4"	Gas
85.149.005B	LWD3020E	3.0	2,000	3	3,400	5/8"	Elec.

Model	Seal Kit	Valve Kit	Oil Cap	Unloader	Piston
LWDK Models	5019003500	KIT001	3200005100	1215027100	0202002000
LWD Models	5019003500	KIT001	3200005100	85.300.003	0202002000



BARE PUMPS AVAILABLE ON REQUEST.

PACKAGING: Boxed

ZWD SERIES

Reinforced and enlarged crankcase for better lubrication gives ZWD a tough edge that has made it the biggest seller in its class.



▼ Part#	Model	GPM	PSI	HP	RPM	Shaft	Motor
85.149.011B	ZWD3030G	3.0	3,000	9	3,400	1"	Gas
85.149.050B	ZWD3535G	3.5	3,500	11	3,400	1"	Gas
85.149.012B	ZWD4030G	4.0	3,000	11	3,400	1"	Gas
85.149.022B	ZWD4040G	4.0	4,000	13	3,400	1"	Gas

Model	Seal Kit	Valve Kit	Oil Cap	Unloader	Piston
ZWD3030G	5019006400	KIT001	3200005100	85.300.006	0202002000
ZWD3535G	5019006400	KIT001	3200005100	85.300.006	0202002000
ZWD4030G	5019006400	KIT001	3200005100	85.300.006	0202002000
ZWD4040G	5019006400	KIT001	3200005100	85.300.007	0202002000

FW/HWS SERIES

High quality tapered roller bearings, iodized aluminum crankcase and stainless steel piston guides help build the strength of this "work horse".



▼ Part#	Model	GPM	PSI	HP	RPM	Shaft	Motor
85.149.017B	FWS3530E	3.5	2,700	5-7.5	1,750	1-1/8"	Elec.
85.149.008B	FWS4030E	4.0	3,000	10	1,750	1-1/8"	Elec.
85.149.031B	HWS3540S	3.5	4,000	11/13	1,400	24mm	Gas
85.149.030B	HWS5040S	3.5	4,000	20	1,750	24mm	Gas

Model	Seal Kit	Valve Kit	Oil Cap	Unloader	Piston
FWS3530E	5019003800	KIT001	3200005100	85.300.006	0202002200
FWS4030E	5019003800	KIT001	3200005100	85.300.006	0202002200
HWS3540S	5109063100	KIT001	3200005100	85.300.012	0202002200
HWS5040S	5109063100	KIT001	3200005100	AL607	0202002200

TW SERIES

It's here. The first pump in the industry with a true "bumper to bumper" warranty. Everything about this pump truly makes it belong as the "Premium Series" pump.



▼ Part#	Model	GPM	PSI	HP	RPM	Shaft	Motor
85.149.059B	TW5050	5.2	5,000	24	1,450	24mm	Gas

Model	Seal Kit	Valve Kit	Unloader	Piston
TW5050	5019064500	5025002100	85.300.013	0202004200

▼ Part#	Shaft	Engine Size
5005020700	1"	Standard
5005023100	1"	20HP
5005023300	1-1/8"	24HP

GEARBOX





BARE PUMPS AVAILABLE ON REQUEST.

PACKAGING: Boxed



TP SERIES

Oversized connecting rods for ultimate crankcase performance. Solid ceramic plungers continuously lubricate packings. Ideal for all general cleaning applications, commercial or residential.



▼ Part#	Model	GPM	PSI	HP	RPM	Shaft	Motor
85.139.020B	TP2530J34UIL	3.0	2,500	5.5-6.5	3,400	3/4"	Gas

Model	Seal Kit	Valve Kit	Oil Cap	Unloader	Piston
TP2530J34UIL	RKI097	KIT123	98210300	RKI102	51040009



EZ/TX SERIES

Solid ceramic plungers. Oversized bearings with greater load capacity means longer life. Longer life low and high pressure seals.



▼ Part#	Model	GPM	PSI	HP	RPM	Shaft	Motor
85.139.002B	TX1510G8	4.0	3,000	11	3,400	1"	Gas
85.139.021B	EZ4040G	4.0	4,000	13	3,400	1"	Gas

Model	Seal Kit	Valve Kit	Oil Cap	Unloader	Piston
TX1510G8	RKI160	KIT123	98210300	85.300.006	52040009
EZ4040G	RKI153	KIT123	98210300	85.300.007	44040266



T SERIES

Forged brass manifold. Large capacity oil bath crankcase. Oversized connecting rods for maximum life. Heavy duty tapered roller bearings.



▼ Part#	Model	GPM	PSI	HP	RPM	Shaft	Motor
85.139.019B	T9281	4.0	4,000	18-20	1,750	24mm	Gas
85.139.018B	T5050	5.0	5,000	24	1,845	24mm	Gas

Model	Seal Kit	Valve Kit	Oil Cap	Unloader	Piston
T9281	RKI109	KIT001	98210600	85.300.007	47040856
T5050	RKI109	RKI150	98210600	85.300.013	47040856



TS SERIES

Forged brass manifold. Large capacity, die-cast, anodized aluminum oil bath crankcase. Oversize connecting rods for maximum life. Heavy duty tapered roller bearings. Solid ceramic plungers with continually lubricated packings.



▼ Part#	Model	GPM	PSI	HP	RPM	Shaft	Motor
85.139.005B	TS-1511	4.0	3/3,500	11/13	1,450	24mm	Gas
85.139.026B	TS-2021	5.6	3,500	20	1,450	32mm	Gas

Model	Seal Kit	Valve Kit	Oil Cap	Unloader	Piston
TS-1511	RKI069	KIT001	98210600	85.300.012	47040409
TS-2021	RKI069	KIT001	98210600	AL607	47040409



PACKAGING: Boxed

SEAL KITS, CAT PUMPS



▼ Part#	Pump Models
30305	10FR, 280, 290
30610	51, 55, 55, 58
30623	30, 31, 34, 35, 210
30629	45
30798	650
30799	56, 57, 59, 60, 60G
30914	230, 240, 270
31040	3531, 3535, 3537
33053	2DX, 2X
33628	5CP2120
33629	5CP3120
33916	1050, 1051, 1057
34053	2SF, 2SFX
34054	4SF
34062	4HP, 5DX
34153	317
34262	6DX

VALVE KITS, CAT PUMPS



▼ Part#	Pump Models
30683	43hs, 45 [2/pump]
30686	280, 290, 333, 430
30820	7 frame, 650 [2/pump]
30821	310, 340, 350 [2/pump]
30915	230, 240, 270
33056	2X [2/pump]
33057	2DX
33060	5CP3120 [2/pump]
33820	56, 57, 59, 60 [2/pump]
34052	2SF
34055	4SF
34056	2SFX
34060	4HP, 5DX [2/pump]
34668	Inlet valve 2SF, 2SFX
34920	1050
34260	6DX [2/pump]

GENERAL KITS, GENERAL PUMPS



▼ Part#	Description
KIT001	Check valves (6) valve kit for TS1511, TT2028, T9281, TS2021
RKI002	Piston guide oil seal
RKI003	Crankshaft oil seal (2)
RKI004	Valve caps & O-rings (6)
RKI006	Piston bolt assembly (3)
RKI007	Head rings (6)
RKI008	20mm packing (3)
RKI010	20mm packing retainer (3)
RKI011	22mm head ring (6)
RKI012	22mm packing (6)
RKI015	24mm head rings (6)
RKI016	24mm packing (6)
RKI019	20mm packing (3)
RKI021	Head rings (6)
RKI023	Oil seals (3)
RKI028	20mm packing assembly (1 cyl) seal kit for TS-1511 & TS2021 (3)
RKI029	22mm packing assembly (1 cyl)
RKI030	24mm packing assembly (1)
RKI069	20mm packing with restop (3)
RKI070	K-7 Unloader repair kit
RKI071	Intermediate ring with restop (3)
RKI079	45mm seal with restop (3)
RKI083	Piston rod oil seal (3)
RKI084	Valve cap assembly (6)
RKI086	15mm packing retainer (3)
RKI087	15mm packing assembly (3)

▼ Part#	Description
RKI088	15mm packing (new) (3)
RKI090	EX pump head rings (6)
RKI092	15mm packing assembly
RKI093	W2 unloader rebuild kit
RKI094	W2 unloader repair kit (1)
RKI095	KR unloader (1)
RKI096	15mm packing assembly (1 cyl) for TP2530 (1)
RKI097	Seal kit for TT2028 (3) 15mm packing assembly
RKI102	TT unloader maintenance kit (1)
RKI108	Head rings T9028 pump
RKI109	16mm packing (new) seal kit for T9281 (3)
RKI112	Seal kit for T9281 (1)
RKI117	Valve kit (6)
KIT123	Valve kit EZ pumps (6)
RKI124	Valve caps EZ pumps (6)
RKI128	Seal kit for TS-2021
RKI130	15mm packing assembly EZ Seal (1)
RKI132	Unloader kit (1)
RKI134	Valve (6)
RKI135	Repair kit
RKI146	Packing (3)
RKI147	Oil seal
RKI150	Valve kit for T5050 (6)
RKI151	Seal kit for T5050 (1)
RKI156	Seal kit for EZ4040G (1)
RKI166	Seal kit for TX1508G8
RKI167	Seal kit for TX1510G8



PACKAGING: Boxed

SEAL KITS, COMET PUMPS



▼ Part#	Pump Models
5019003500	LWDK3020G
5019003500	LWDK3025G
5019003500	LWDK2020E
5019003800	FWD4030G
5019003800	FWS4030E
5019006400	ZWD2530G
5019006400	ZWD3030G
5019006400	ZWD4030G
5019006400	ZWD4040G
5019007700	AXD2518G
5019007700	AXD2424G
5019007700	AXD3025G
5019008600	AXD3030G
5019008600	AXD3530G
5019008600	AXD4030G
5019007700	AXD2020E
5019007700	AXD3020E
5019063100	HWS3540S
5019063100	HWS5040S

VALVE KITS, COMET PUMPS



▼ Part#	Pump Models
KIT001	All Non-AXD Pumps
5025001400	All AXD Pumps

OIL CAP, CAT



Part#	46798
Pumps	5DX, 66DX, 5CP

OIL CAP, CAT



Part#	45690
Pumps	2SF, 4SF, 2DX

OIL CAP, GENERAL



Part#	98210300
Pumps	Most General Pumps

OIL CAP, COMET



Part#	3200005100
Pumps	All Comet Triplex

OIL CAP, COMET



Part#	3200007100
Pumps	All Comet AXD Pumps

Part# For All Pumps

85.490.042 Anti-Freeze Solution

Use of this product will prolong your pressure washer's pump life and prevent freeze damage.





SECTION 5

BASIC ACCESSORIES

BASIC ACCESSORIES

Spray Guns	76
Wands and Lances	78
Wands and Handles	79
Low Pressure Spray Kits	80
Packaged Parts Profile	80
Spray Nozzles, Quick Connect	82
Spray Nozzles, Meg	83
Nozzles and Holders	84
Rotary Nozzles	85
High Pressure Hoses	86
Low Pressure Hoses	87





PACKAGING: Packaged

"BE" INDUSTRIAL SPRAY GUN*Ideal for Hot and Cold water applications*

Part#	85.202.108
Max Pressure	5,000 PSI
Max Temperature	300° F
Max Flow	8 GPM
Outlet	1/4" FNPT
Inlet	3/8" FNPT
Repair Kit	85.201.005
Weight	1.26 lbs

MV 880 SPRAY GUN

Part#	85.202.001
Max Pressure	4,000 PSI
Max Temperature	300° F
Max Flow	12 GPM
Outlet	1/4" FNPT
Inlet	3/8" FNPT
Repair Kit	85.201.001
Weight	1.26 lbs

MV 920 SPRAY GUN

Part#	85.202.010
Max Pressure	4,000 PSI
Max Temperature	300° F
Max Flow	8 GPM
Outlet	1/4" FNPT
Inlet	3/8" FNPT
Repair Kit	85.201.003
Weight	1.26 lbs

"BE" FRONT LOAD SPRAY GUN

Part#	85.202.018
Max Pressure	2,750 PSI
Max Temperature	210° F
Max Flow	7 GPM
Outlet	3/8" FNPT
Inlet	1/4" FNPT
Repair Kit	85.201.006
Weight	0.9 lbs



PACKAGING: Packaged

“BE” WEEPING SPRAY GUN



Part#	85.202.064
Max Pressure	5,000 PSI
Max Temperature	300° F
Max Flow	10 GPM
Outlet	1/4" FNPT
Inlet	3/8" FNPT
Repair Kit	85.201.007
Weight	1.5 lbs

“BE” HORIZONTAL SPRAY GUN



Part#	85.202.063
Max Pressure	5,000 PSI
Max Temperature	300° F
Max Flow	10 GPM
Outlet	1/4" FNPT
Inlet	3/8" FNPT
Repair Kit	85.201.008
Weight	1.5 lbs

LONG WAND SPRAY GUN 2004



REPAIR KITS	Part#
Repair kit	85.201.003
Gun housing	85.202.012
Gun/trigger, insert	85.202.011
3/8" male plug	85.300.105
Brass elbow	85.704.004

Part#	85.202.113
Max Pressure	4,000 PSI
Max Temperature	300° F
Max Flow	7 GPM
Outlet	3/8" Plug
Inlet	1/4" FNPT
Weight	1.73 lbs

THREADED LONG WAND SPRAY GUN 2005



REPAIR KITS	Part#
Repair kit	85.201.005
Gun housing	85.202.068

Part#	85.202.114
Max Pressure	5,000 PSI
Max Temperature	300° F
Max Flow	10 GPM
Outlet	1/4" FNPT
Inlet	3/8" FNPT
Weight	2.12 lbs



PACKAGING: Packaged

DOUBLE WAND

1/4" chrome plated pipe with molded grip. Control handle allows easy soap or chemical application. *Nozzle tips are not supplied.*



Part#	85.202.054
Max Pressure	3,000 PSI
Max Temperature	300° F
Max Flow	12 GPM
Weight	2.53 lbs

GUN AND DOUBLE WAND

1/4" chrome plated pipe with molded grip. Control handle allows easy soap or chemical application. *Nozzle tips are not supplied.*



Part#	85.205.054
Max Pressure	3,000 PSI
Max Temperature	300° F
Max Flow	12 GPM
Weight	3.58 lbs

PARTS INCLUDED	Part#
Wand	85.202.054
Spray Gun	85.202.108
3/8" Male Plug	85.300.105

GUN AND WAND ASSEMBLIES

Complete assemblies of gun and wands with quick disconnect couplers.



▼ Part#	Length	Wand#	Weight
85.205.026	36"	85.202.026	3.08 lbs
85.205.027	47"	85.202.027	4.36 lbs
85.205.028	59"	85.202.028	4.64 lbs
85.205.029	79"	85.202.029	5.20 lbs

COMPONENTS	Part#
Spray Gun	85.202.108
Coupler	85.300.102
3/8" Male Plug	85.300.105

INSULATED WANDS

Bare lance 1/4" MNPT thread.



▼ Part#	▼ Part#	Length	Weight
Stainless Steel	Standard		
85.202.026S	85.202.026	900mm / 36"	1.32 lbs
85.202.027S	85.202.027	1,200mm / 47"	1.92 lbs
85.202.028S	85.202.028	1,500mm / 59"	2.30 lbs
85.202.029S	85.202.029	2,000mm / 79"	2.96 lbs

ALL WANDS	Standard	Stainless Steel
Max Pressure	4,000 PSI	5,000 PSI
Max Flow	12 GPM	12 GPM
Max Temperature	300° F	300° F



PACKAGING: Packaged

ALUMINUM WANDS

Bare lance, 1/4" aluminum MNPT thread, schedule 80 pipe.



Part#	Length	Weight
85.202.093	900mm / 36"	0.70 lbs
85.202.094	1,200mm / 47"	0.95 lbs
85.202.095	1,500mm / 59"	1.20 lbs
85.202.096	1,800mm / 72"	1.30 lbs
85.202.097	2,000mm / 79"	1.50 lbs

ALL WANDS

Max Pressure	4,000 PSI
Max Flow	12 GPM
Max Temperature	300° F

FLEX WANDS



Part#	85.202.022
Max Pressure	4,000 PSI
Length	20"
Size	1/4" MNPT
Weight	1 lbs

LANCE HANDLES, SCREW TYPE, RUBBER

Fits on any standard pressure washer lance for extra hold.



Part#	85.202.045
Weight	0.36 lbs

ACCESSORY KIT

The ideal kit for use with little electric hobby plastic pressure washers.



Part#	85.400.327
Weight	6 lbs

Component	Part#
Front Load Gun (2750 PSI)	85.202.018
Split Lance	85.205.063
M22 Coupler	85.300.125
Vari-Nozzle #3	85.210.007
25 ft. hose (3000 PSI)	85.225.225

FLEX WAND, RUBBER CASING



Part#	85.202.062
Max Pressure	2,250 PSI
Length	16.5"
Size	1/4" MNPT
Weight	0.91 lbs

LANCE HANDLE, C-CLAMP, PLASTIC

Fits on any standard pressure washer lance for extra hold.



Part#	85.202.066
Weight	0.36 lbs



PACKAGING: Packaged

BACKPACK SPRAYER

Lever action piston pump with quick fitting harness.



Part#	90.700.015
Capacity	15 Litre / 4 Gallons
Pressure	15 - 90 PSI
Nozzles	4

HANDHELD C5 SPRAYER



▼ Part#	Capacity	Pressure	Nozzles
90.700.065	6.5 Litres / 1.7 Gal.	55 PSI	2
90.700.008	8.0 Litres / 2 Gal.	55 PSI	2

STAINLESS STEEL SPRAYERS WITH GAUGE



▼ Part#	Capacity	Pressure	Nozzles
90.701.004	4 Litres / 1 Gal.	40 PSI	1
90.701.006	6 Litres / 1.5 Gal.	40 PSI	1
90.701.008	8 Litres / 2 Gal.	40 PSI	1
90.701.010	10 Litres / 2.5 Gal.	40 PSI	1

HANDHELD SPRAYER



Part#	90.700.012
Capacity	1.2 Litre / 0.3 Gallons
Pressure	10 PSI
Nozzles	1

SPOT SPRAYER

Low pressure gun to fit 3/8" hose

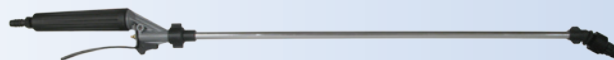

Part#	U45050000
Inlet	3/8" Hose barb
Material	Aluminum wand
Max Flow	12 GPM
Weight	0.42 lbs



Packaged Parts

BE Pressure Washing
ACCESSORIES



GROW YOUR PARTS BUSINESS

Put the BE Accessory Rack in your showroom to display your parts showing your customers all the available options.





PACKAGING: Packaged

SPRAY NOZZLE, QUICK CONNECT



▼ Part#	Size
85.201.020	020
85.201.025	025
85.201.030	030
85.201.035	035
85.201.040	040
85.201.045	045
85.201.050	050
85.201.055	055
85.201.060	060
85.201.065	065
85.201.070	070
85.201.075	075
85.201.080	080
85.201.085	085
85.201.090	090

▼ Part#	Size
85.216.020	020
85.216.025	025
85.216.030	030
85.216.035	035
85.216.040	040
85.216.045	045
85.216.050	050
85.216.055	055
85.216.060	060
85.216.065	065
85.216.070	070
85.216.075	075
85.216.080	080
85.216.085	085
85.216.090	090

▼ Part#	Size
85.226.020	020
85.226.025	025
85.226.030	030
85.226.035	035
85.226.040	040
85.226.045	045
85.226.050	050
85.226.055	055
85.226.060	060
85.226.065	065
85.226.070	070
85.226.075	075
85.226.080	080
85.226.085	085
85.226.090	090

▼ Part#	Size
85.241.020	020
85.241.025	025
85.241.030	030
85.241.035	035
85.241.040	040
85.241.045	045
85.241.050	050
85.241.055	055
85.241.060	060
85.241.065	065
85.241.070	070
85.241.075	075
85.241.080	080
85.241.085	085
85.241.090	090

NOZZLE SIZE CHART

Match your PSI with your GPM to determine correct nozzle size.

PSI ▶	1,000	2,000	3,000	4,000	5,000
Size	GPM ▼	GPM ▼	GPM ▼	GPM ▼	GPM ▼
020	1.00	1.41	1.73	2.00	2.24
025	1.25	1.77	2.17	2.50	2.80
030	1.50	2.12	2.60	3.00	3.35
035	1.75	2.47	3.03	3.50	3.91
040	2.00	2.83	3.46	4.00	4.47
045	2.25	3.18	3.90	4.50	5.03
050	2.50	3.54	4.33	5.00	5.59
055	2.75	3.89	4.76	5.50	6.15
060	3.00	4.24	5.20	6.00	6.71
065	3.25	4.60	5.63	6.50	7.27
070	3.50	4.95	6.06	7.00	7.83
075	3.75	5.30	6.50	7.50	8.39
080	4.00	5.66	6.93	8.00	8.94
085	4.25	6.01	7.36	8.50	9.50
090	4.50	6.36	7.79	9.00	10.06
100	5.00	7.07	8.66	10.00	11.18

CHEMICAL NOZZLE, QUICK CONNECT

Used to apply soap and chemicals.



Part#	85.266.400
Inlet	1/4" Quick Connect
Material	Brass, Plastic #40
Weight	0.04 lbs



PACKAGING: Packaged

SPRAY NOZZLE, MEG

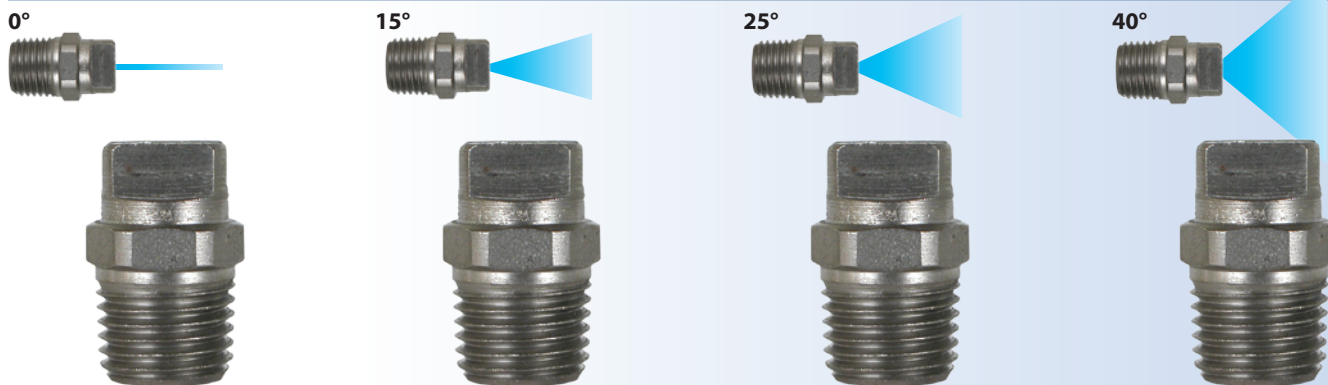

▼ Part#	Size
85.200.020	020
85.200.025	025
85.200.030	030
85.200.035	035
85.200.040	040
85.200.045	045
85.200.050	050
85.200.055	055
85.200.060	060
85.200.065	065
85.200.070	070
85.200.075	075
85.200.080	080
85.200.085	085
85.200.090	090

▼ Part#	Size
85.215.020	020
85.215.025	025
85.215.030	030
85.215.035	035
85.215.040	040
85.215.045	045
85.215.050	050
85.215.055	055
85.215.060	060
85.215.065	065
85.215.070	070
85.215.075	075
85.215.080	080
85.215.085	085
85.215.090	090

▼ Part#	Size
85.225.020	020
85.225.025	025
85.225.030	030
85.225.035	035
85.225.040	040
85.225.045	045
85.225.050	050
85.225.055	055
85.225.060	060
85.225.065	065
85.225.070	070
85.225.075	075
85.225.080	080
85.225.085	085
85.225.090	090

▼ Part#	Size
85.240.020	020
85.240.025	025
85.240.030	030
85.240.035	035
85.240.040	040
85.240.045	045
85.240.050	050
85.240.055	055
85.240.060	060
85.240.065	065
85.240.070	070
85.240.075	075
85.240.080	080
85.240.085	085
85.240.090	090

NOZZLE SIZE CHART

Match your PSI with your GPM to determine correct nozzle size.

PSI ▶	1,000	2,000	3,000	4,000	5,000
Size	GPM ▼	GPM ▼	GPM ▼	GPM ▼	GPM ▼
020	1.00	1.41	1.73	2.00	2.24
025	1.25	1.77	2.17	2.50	2.80
030	1.50	2.12	2.60	3.00	3.35
035	1.75	2.47	3.03	3.50	3.91
040	2.00	2.83	3.46	4.00	4.47
045	2.25	3.18	3.90	4.50	5.03
050	2.50	3.54	4.33	5.00	5.59
055	2.75	3.89	4.76	5.50	6.15
060	3.00	4.24	5.20	6.00	6.71
065	3.25	4.60	5.63	6.50	7.27
070	3.50	4.95	6.06	7.00	7.83
075	3.75	5.30	6.50	7.50	8.39
080	4.00	5.66	6.93	8.00	8.94
085	4.25	6.01	7.36	8.50	9.50
090	4.50	6.36	7.79	9.00	10.06
100	5.00	7.07	8.66	10.00	11.18

CHEMICAL NOZZLE, MEG

Used to apply soap and chemicals.

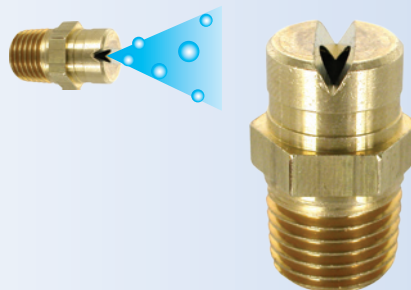

Part#	85.240.300
Inlet	1/4" MNPT
Material	Brass
Weight	0.04 lbs



PACKAGING: Packaged

LASER NOZZLE, DRAIN CLEANING

Allows you to effectively clear clogged drain pipes.



▼ Part#	Size	PSI	Temp.	Weight
85.210.146	1/8"	4,000	300° F	0.02 lbs
85.210.156	1/8"	4,000	300° F	0.02 lbs
85.210.246	1/4"	4,000	300° F	0.02 lbs
85.210.256	1/4"	4,000	300° F	0.02 lbs

STAINLESS STEEL ROLL-OVER NOZZLE

Allows you to easily switch between 2 nozzles.

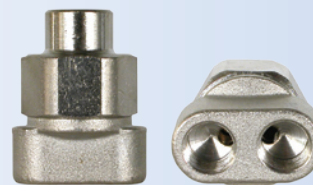

Part#	85.210.000
Max Pressure	3,000 PSI
Max Temperature	140° F
Max Flow	7 GPM
Inlet	1/4" FNPT
Fittings (2)	1/4" FNPT
Material	Stainless Steel
Weight	0.36 lbs

NOZZLE HOLDER, LANCE MOUNTED



Part#	85.210.014
Number of Nozzle Slots	7 (does not come with nozzles)
Material	Stainless Steel
Weight	0.53 lbs

ADJUSTABLE NOZZLE HOLDER



Part#	85.210.001
Max Pressure	3,650 PSI
Max Flow	8 GPM
Weight	0.25 lbs

VARIABLE-NOZZLES



Part#	85.210.007
Size	1.05mm #3
GPM	1.58-3.12

Part#	85.210.002
Size	1.20mm #4
GPM	2.00-3.44

Part#	85.210.003
Size	1.30mm #4.5
GPM	2.32-3.96

Part#	85.210.005
Size	1.35mm #5
GPM	2.58-4.32

Part#	85.210.006
Size	1.45mm #5.5
GPM	2.80-4.76

ALL VARI-NOZZLES

Temperature 300° F

Inlet 1/4" FNPT

Weight 0.34 lbs



PACKAGING: Packaged

ROTARY NOZZLE, SMALL ASSEMBLY



Part#	85.210.170
Max Pressure	2,500 PSI
Max Temperature	300° F
Max Flow	4 GPM
Inlet	1/4" quick-connect
Nozzle	Ceramic
Repair Kit#	85.211.005
Weight	0.90 lbs

ROTARY NOZZLE, SMALL ASSEMBLY



Part#	85.210.180
Max Pressure	3,000 PSI
Max Temperature	130° F
Max Flow	4 GPM
Inlet	1/4" quick-connect
Nozzle	Ceramic
Repair Kit#	85.211.005
Weight	0.90 lbs

ROTARY NOZZLE, MEDIUM ASSEMBLY



Part#	85.210.190
Max Pressure	4,000 PSI
Max Temperature	130° F
Max Flow	4 GPM
Inlet	1/4" quick-connect
Nozzle	Ceramic
Repair Kit#	85.211.003
Weight	1.08 lbs

ROTARY NOZZLE, LARGE ASSEMBLY



Part#	85.210.011
Max Pressure	5,000 PSI
Max Temperature	130° F
Max Flow	4.5 GPM
Inlet	1/4" quick-connect
Nozzle	Ceramic
Repair Kit#	85.211.004
Weight	0.90 lbs

ROTARY NOZZLE, STAINLESS STEEL ASSEMBLY



Part#	85.210.012
Max Pressure	7,350 PSI
Max Temperature	130° F
Max Flow	5 GPM
Inlet	1/4" quick-connect
Nozzle	Ceramic
Repair Kit#	85.211.002
Weight	1.6 lbs

FILTER, INLINE HIGH PRESSURE

Protects the system from contaminants in the water.



Part#	85.211.007	1/4" Quick Connect
Part#	85.211.006	1/4" FNPT
Max Pressure	5,500 PSI	
Max Temperature	200° F	
Max Flow	8 GPM	
Inlet	1/4"	
Outlet	1/4" MNPT	
Weight	0.23 lbs	



PACKAGING: Packaged

HIGH PRESSURE HOSE, HOT/COLD WATER ASSEMBLY



▼ Part#	Couplers	Length	Size	Weight
85.256.126*	Brass	25'	5/16"	4.64 lbs
85.256.125	None	25'	5/16"	4.36 lbs
85.238.151*	Brass	50'	3/8"	10.24 lbs
85.238.150	None	50'	3/8"	9.96 lbs
85.238.111	Brass	100'	3/8"	18.68 lbs
85.238.110	None	100'	3/8"	18.6 lbs

* Boxed Packaging

SPECIFICATIONS

Wire Braid	Single Wire Braid
Max Pressure	4,000 PSI
Max Temperature	200° F

HIGH PRESSURE HOSE, HOT/COLD WATER ASSEMBLY



▼ Part#	Couplers	Length	Weight
85.238.251	Stainless Sleeve	50'	15.56 lbs
85.238.250	None	50'	15.48 lbs
85.238.211	Stainless Sleeve	100'	30.28 lbs
85.238.210	None	100'	30.20 lbs

SPECIFICATIONS

Wire Braid	Double Wire Braid
Max Pressure	5,000 PSI
Max Temperature	200° F
Size	3/8"

HIGH PRESSURE HOSE, NON-MARKING ASSEMBLY



▼ Part#	Couplers	Length	Weight
85.238.155	Stainless Sleeve	50'	11.44 lbs
85.238.154	None	50'	11.14 lbs
85.238.156*	Stainless Sleeve	50'	11.84 lbs

* Boxed Packaging

SPECIFICATIONS

Wire Braid	Single Wire Braid
Max Pressure	4,000 PSI
Max Temperature	250° F
Size	3/8"

HIGH PRESSURE HOSE, SEWER CLEANING ASSEMBLY



▼ Part#	Description	Length	Weight
85.236.050	1/8" MNPT	50'	2.39 lbs
85.236.100	1/8" MNPT	100'	4.77 lbs

SPECIFICATIONS

Max Pressure	2,900 PSI
Max Temperature	195° F
Size	3/16"



PACKAGING: Packaged

DISCHARGE HOSE KITS

Temperature Rating: 150° F



▼ Part#	Length	Size	Pressure	Weight
85.400.080	25 ft.	1"	80 PSI	10.5 lbs
85.400.081	25 ft.	2"	80 PSI	11.0 lbs
85.400.082	25 ft.	3"	65 PSI	11.5 lbs
85.400.083	25 ft.	4"	55 PSI	12.0 lbs
85.400.084	50 ft.	1"	80 PSI	21.0 lbs
85.400.085	50 ft.	2"	80 PSI	22.0 lbs
85.400.086	50 ft.	3"	65 PSI	23.0 lbs
85.400.087	50 ft.	4"	55 PSI	24.0 lbs

INDUSTRIAL DISCHARGE HOSE KITS

Temperature Rating: 150° F

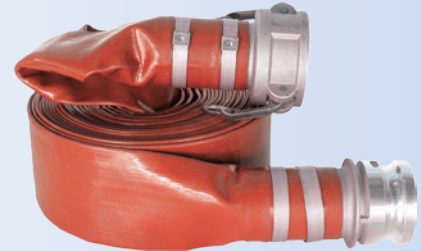

▼ Part#	Length	Size	Pressure	Weight
85.400.092	25 ft.	1"	150 PSI	11.0 lbs
85.400.093	25 ft.	2"	150 PSI	11.5 lbs
85.400.094	25 ft.	3"	150 PSI	12.0 lbs
85.400.095	25 ft.	4"	150 PSI	12.5 lbs
85.400.096	50 ft.	1"	150 PSI	22.0 lbs
85.400.097	50 ft.	2"	150 PSI	23.0 lbs
85.400.098	50 ft.	3"	150 PSI	24.0 lbs
85.400.099	50 ft.	4"	150 PSI	25.0 lbs

DISCHARGE HOSE, BULK

Light weight PVC lays flat and rolls up tightly for storage.



▼ Part#	Length	Size	Pressure	Weight
G971-125	25 ft.	1"	80 PSI	8.5 lbs
G971-225	25 ft.	2"	80 PSI	9 lbs
G971-325	25 ft.	3"	65 PSI	9 lbs
G971-425	25 ft.	4"	55 PSI	9.5 lbs
G971-100	50 ft.	1"	80 PSI	17 lbs
G971-200	50 ft.	2"	80 PSI	18 lbs
G971-300	50 ft.	3"	65 PSI	18 lbs
G971-400	50 ft.	4"	55 PSI	19 lbs

INDUSTRIAL DISCHARGE HOSE, BULK

Light weight PVC lays flat and rolls up tightly for storage.



▼ Part#	Length	Size	Pressure	Weight
G972-125	25 ft.	1"	150 PSI	9 lbs
G972-225	25 ft.	2"	150 PSI	9 lbs
G972-325	25 ft.	3"	150 PSI	9.5 lbs
G972-425	25 ft.	4"	150 PSI	9.5 lbs
G972-100	50 ft.	1"	150 PSI	17 lbs
G972-200	50 ft.	2"	150 PSI	18 lbs
G972-300	50 ft.	3"	150 PSI	18 lbs
G972-400	50 ft.	4"	150 PSI	18.5 lbs

SUCTION HOSE KITS



▼ Part#	Length	Size	Weight
85.400.088	25 ft.	1"	5 lbs
85.400.089	25 ft.	2"	12 lbs
85.400.090	25 ft.	3"	16 lbs
85.400.091	25 ft.	4"	20 lbs

SUCTION HOSE, BULK

Made of clear, flexible PVC hose, lightweight and non-marking. Ideal for general pump suction.

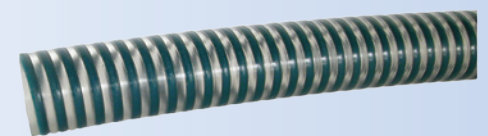

▼ Part#	Size	Weight/ft.
G941K-100	1" diameter	0.17 lbs
G941K-200	2" diameter	0.22 lbs
G941K-300	3" diameter	0.61 lbs
G941K-400	4" diameter	1.09 lbs



SECTION 6

VALVES AND FITTINGS

VALVES AND FITTINGS

Unloaders	90
Ball Valves	92
Valves	94
Valves and Chemical Injectors	95
Orings	96
Sure-Lock Couplers	97
Couplers and Plugs	98
Fittings	99
Garden Hose and Nozzle Fittings	100
Nozzle Fittings and Screens	101



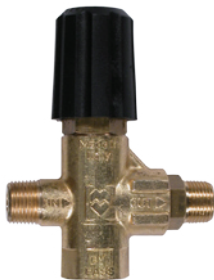

PACKAGING: Packaged

UNLOADER, MV 540

Part#	85.300.003
Max Pressure	2,500 PSI
Max Temperature	200° F
Max Flow	8 GPM
Inlet/Outlet	3/8" MNPT
Bypass	3/8" FNPT
Weight	0.9 lbs

REPAIR KITS	Part#
Repair Kit	85.301.002
Black Plastic Knob	119740010

UNLOADER, MV 550

Part#	85.300.001
Max Pressure	3,600 PSI
Max Temperature	200° F
Max Flow	8 GPM
Inlet/Outlet	3/8" MNPT
Bypass	1/4" FNPT
Weight	1.65 lbs

REPAIR KITS	Part#
Repair Kit	85.301.005
Black Plastic Knob	119000010
Seal Kit	85.300.010

UNLOADER, MV 590 'EZ-START'

Comes with built-in thermal valve and adjustable chemical injector.



Part#	85.300.006
Max Pressure	3,600 PSI
Max Temperature	145° F
Max Flow	8 GPM
Inlet/Outlet	3/8" MNPT
Bypass	1/4" FNPT
Weight	2.2 lbs

REPAIR KITS	Part#
Repair Kit	85.301.005
Red Plastic Knob	0119000120
Seal Kit	85.300.010
Thermal Valve Repair Kit	0215102900
Soap Injector Kit	0203100020

UNLOADER, MV 595 'EZ-START'

Comes with built-in thermal valve (145° F) and safety relief valve.



Part#	85.300.007
Max Pressure	4,000 PSI
Max Temperature	145° F
Max Flow	8 GPM
Inlet/Outlet	3/8" FNPT
Bypass	1/4" FNPT
Weight	2.4 lbs

REPAIR KITS	Part#
Repair Kit	85.301.006
Red Plastic Knob	0119000170
Thermal Valve Repair Kit	0215102900
Safety Valve Repair Kit	0215102820

UNLOADER, MV 595B 'EZ-START'

Comes with built-in thermal valve (145° F) and safety relief valve.



Part#	85.300.012
Max Pressure	4,000 PSI
Max Temperature	145° F
Max Flow	8 GPM
Inlet/Outlet	3/8" MNPT
Bypass	1/4" FNPT
Weight	2.4 lbs

REPAIR KITS	Part#
Repair Kit	85.301.006
Red Plastic Knob	0119000170
Thermal Valve Repair Kit	0215102900
Safety Valve Repair Kit	0215103300

UNLOADER, MV 580

Part#	85.300.005
Max Pressure	4,000 PSI
Max Temperature	200° F
Max Flow	8 GPM
Inlet/Outlet	3/8" MNPT
Bypass	1/4" FNPT
Weight	2.1 lbs

REPAIR KITS	Part#
Repair Kit	85.301.005
Black Plastic Knob	119000010
Seal Kit	85.300.010



PACKAGING: Packaged

UNLOADER, ARROWLINE



Part#	AL607
Max Pressure	4,200 PSI
Max Temperature	190° F
Max Flow	7.8 GPM
Inlet/Outlet	3/8" FNPT
Bypass	3/8" FNPT
Weight	2.1 lbs

REPAIR KITS	Part#
Repair Kit	005-650200

UNLOADER, ARROWLINE 'EZ-START'



Part#	AL607EZ
Max Pressure	4,350 PSI
Max Temperature	190° F
Max Flow	7.8 GPM
Inlet/Outlet	3/8" FNPT
Bypass	3/8" FNPT
Weight	2.1 lbs

REPAIR KITS	Part#
Repair Kit	005-650200

UNLOADER, ARROWLINE 5000 PSI



Part#	85.300.013
Max Pressure	5,000 PSI
Max Temperature	190° F
Max Flow	7.8 GPM
Inlet/Outlet	3/8" FNPT
Bypass	3/8" FNPT
Weight	2.1 lbs

REPAIR KITS	Part#
Repair Kit	005-650200

UNLOADER, PA 7535



Part#	85.310.003
Max Pressure	4,000 PSI
Max Temperature	180° F
Max Flow	21 GPM
Inlet/Outlet	1/2" FNPT
Bypass	1/2" FNPT
Weight	3.05 lbs

REPAIR KITS	Part#
Repair Kit	32346

UNLOADER, MTM BP90



Part#	85.300.008
Max Pressure	4,500 PSI
Max Temperature	195° F
Max Flow	8 GPM
Inlet/Outlet	3/8" MNPT
Bypass	1/4" FNPT
Weight	1.92 lbs

REPAIR KITS	Part#
Repair Kit	32346



PACKAGING: Packaged

BALL VALVES, BRASS CSA APPROVED

Full port Brass ball valve.



▼ Part#	Size	PSI	Thread	Weight
91.100.001	1/4"	600	FNPT	0.58 lbs
91.100.002	3/8"	600	FNPT	0.54 lbs
91.100.003	1/2"	600	FNPT	0.72 lbs
91.100.004	3/4"	600	FNPT	1.12 lbs
91.100.005	1"	600	FNPT	1.16 lbs
91.100.007	1 1/2"	600	FNPT	2.76 lbs
91.100.008	2"	600	FNPT	5.14 lbs
91.100.010	3"	600	FNPT	9.90 lbs

BALL VALVES, BRASS

Full port Brass ball valve.



▼ Part#	Size	PSI	Thread	Weight
91.000.001	1/4"	600	FNPT	0.58 lbs
91.000.002	3/8"	600	FNPT	0.54 lbs
91.000.003	1/2"	600	FNPT	0.72 lbs
91.000.004	3/4"	600	FNPT	1.12 lbs
91.000.005	1"	600	FNPT	1.16 lbs
91.000.006	1 1/4"	600	FNPT	2.21 lbs
91.000.007	1 1/2"	600	FNPT	2.76 lbs
91.000.008	2"	600	FNPT	5.14 lbs
91.000.010	3"	600	FNPT	9.90 lbs

BALL VALVES, STAINLESS STEEL

Full port Stainless Steel ball valve.

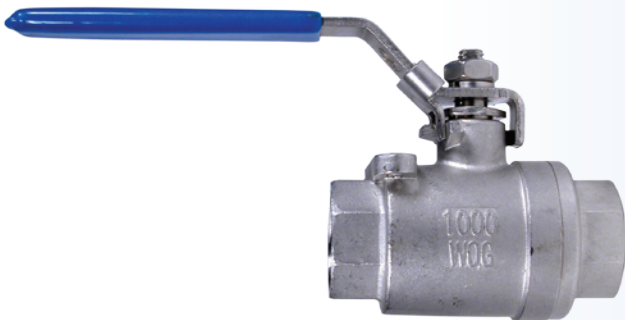

▼ Part#	Size	PSI	Thread	Weight
91.200.001	1/4"	1,000	FNPT	0.20 lbs
91.200.002	3/8"	1,000	FNPT	0.30 lbs
91.200.003	1/2"	1,000	FNPT	0.50 lbs
91.200.004	3/4"	1,000	FNPT	0.70 lbs
91.200.005	1"	1,000	FNPT	1.20 lbs
91.200.006	1 1/4"	1,000	FNPT	1.90 lbs
91.200.007	1 1/2"	1,000	FNPT	2.30 lbs
91.200.008	2"	1,000	FNPT	3.35 lbs
91.200.009	2 1/2"	1,000	FNPT	6.35 lbs
91.200.010	3"	1,000	FNPT	10.7 lbs

BALL VALVES, BLACK CARBON STEEL



▼ Part#	Size	PSI	Thread	Weight
91.300.001	1/4"	2,000	FNPT	0.17 lbs
91.300.002	3/8"	2,000	FNPT	0.16 lbs
91.300.003	1/2"	2,000	FNPT	0.64 lbs
91.300.004	3/4"	2,000	FNPT	1.02 lbs
91.300.005	1"	2,000	FNPT	2.00 lbs
91.300.006	1 1/4"	2,000	FNPT	3.10 lbs
91.300.007	1 1/2"	2,000	FNPT	5.40 lbs
91.300.008	2"	2,000	FNPT	8.30 lbs



PACKAGING: Packaged

BALL VALVES, STEEL

Full port Steel ball valve.

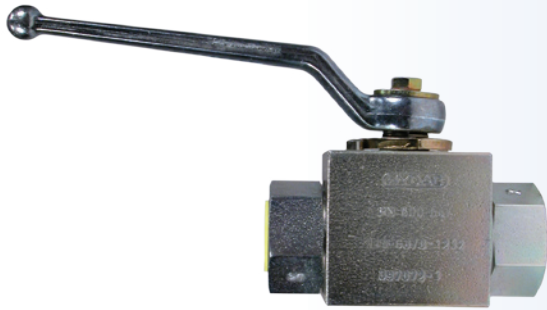

Part#	85.300.046
Max Pressure	7,350 PSI
Thread	3/8" FNPT
Material	Steel
Weight	1.98 lbs

BALL VALVES, STAINLESS STEEL

Full port Stainless Steel ball valve.

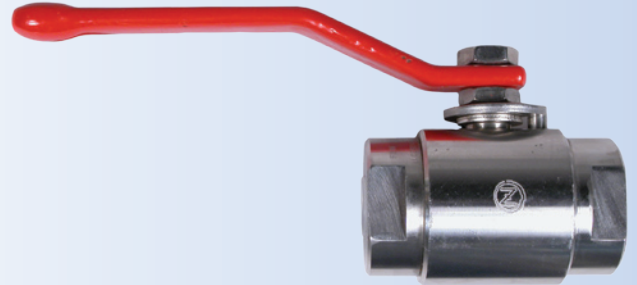

Part#	85.300.046S
Max Pressure	6,000 PSI
Thread	3/8" FNPT
Material	Stainless Steel
Weight	1.98 lbs

BALL VALVES, MINI CHROME

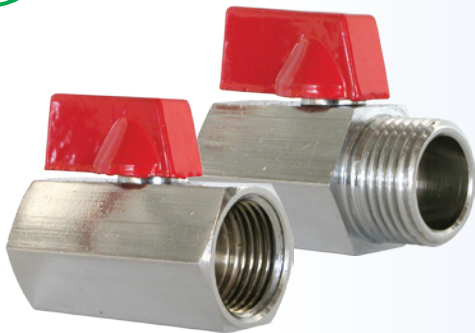

▼ Part#	Size	PSI	Thread
91.400.001	1/4"	200	FNPT x FNPT
91.401.001	1/4"	200	FNPT x MNPT
91.400.002	3/8"	200	FNPT x FNPT
91.401.002	3/8"	200	FNPT x MNPT
91.400.003	1/2"	200	FNPT x FNPT
91.401.003	1/2"	200	FNPT x MNPT

BALL VALVES, NOZZLE

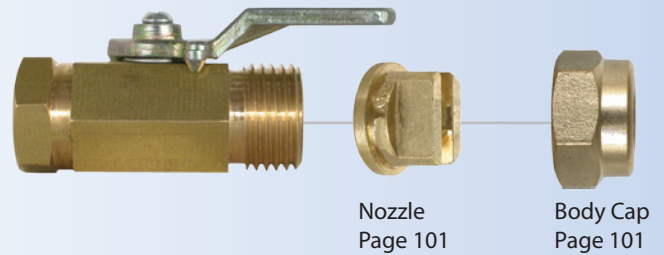

Nozzle
Page 101

Body Cap
Page 101

Part#	90.900.056
Fitting	1/4" FNPT x 1/16" M
Material	Brass



PACKAGING: Packaged

GATE VALVE, BRASS



▼ Part#	Size	PSI	Thread	Weight
92.000.003	1/2"	200	FNPT	0.52 lbs
92.000.004	3/4"	200	FNPT	0.72 lbs
92.000.005	1"	200	FNPT	0.93 lbs
92.000.006	1 1/4"	200	FNPT	1.50 lbs
92.000.007	1 1/2"	200	FNPT	1.85 lbs
92.000.008	2"	200	FNPT	2.82 lbs
92.000.009	2 1/2"	200	FNPT	5.18 lbs
92.000.010	3"	200	FNPT	7.50 lbs
92.000.012	4"	200	FNPT	11.9 lbs

VERTICAL CHECK VALVE

Brass body, Stainless Steel ball



▼ Part#	Size	PSI	Thread	Weight
93.000.002	3/8"	200	FNPT	0.31 lbs
93.000.003	1/2"	200	FNPT	0.30 lbs
93.000.004	3/4"	200	FNPT	0.47 lbs
93.000.005	1"	200	FNPT	0.57 lbs
93.000.006	1 1/4"	200	FNPT	0.89 lbs
93.000.007	1 1/2"	200	FNPT	1.45 lbs
93.000.008	2"	200	FNPT	1.87 lbs

FOOR VALVE

Brass body, Stainless Steel ball



▼ Part#	Size	PSI	Thread	Weight
94.000.003	1/2"	200	FNPT	0.35 lbs
94.000.004	3/4"	200	FNPT	0.52 lbs
94.000.005	1"	200	FNPT	1.03 lbs
94.000.006	1 1/4"	200	FNPT	1.50 lbs
94.000.007	1 1/2"	200	FNPT	2.03 lbs
94.000.008	2"	200	FNPT	2.95 lbs

PULSATION DAMPENER

Mounts to the outlet of the pump to prolong the life of the pump and system.



▼ Part#	85.300.047
Max Pressure	3,100 PSI
Max Temperature	180° F
Pre-charge Pressure	580 PSI
Thread	3/8" FNTP
Volume	0.16 Litre
Weight	1.82 lbs



PACKAGING: Packaged

'EZ-START' VALVE

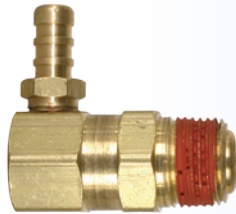

Part#	85.300.035
Inlet	3/8" MNPT
Outlet	1/4" Hose Barb
Weight	0.3 lbs

THERMAL VALVE

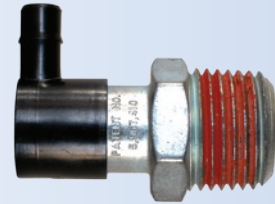

Part#	85.300.023	3/8" MNPT Inlet
Part#	85.300.024	1/2" MNPT Inlet
Max Pressure	200 PSI	
Max Temperature	145° F	
Max Flow	25 GPM	
Weight	0.3 lbs	

JETTER VALVE

Used with drain cleaners. **COMET PUMPS** only.



▼ Part#	Max Pressure	Pump	Weight
85.400.119	3,000 PSI	LWD-K	0.55 lbs
85.400.219	3,500 PSI	ZW / HW	0.90 lbs
85.400.319	3,600 PSI	TW / SW	0.90 lbs

SAFETY RELIEF VALVE

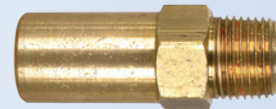

Part#	85.300.042	
Max Pressure	6,000 PSI	
Max Temperature	195° F	
Max Flow	6 GPM	
Inlet	3/8" MNPT	
Weight	0.3 lbs	

ADJUSTABLE CHEMICAL INJECTOR



Part#	85.300.092
Max Pressure	4,000 PSI
Max Temperature	200° F
Max Flow	3-5 GPM
Inlet	3/8" quick connect plug
Outlet	3/8" quick connect coupler
Material	Brass
Weight	0.35 lbs

ADJUSTABLE CHEMICAL INJECTOR

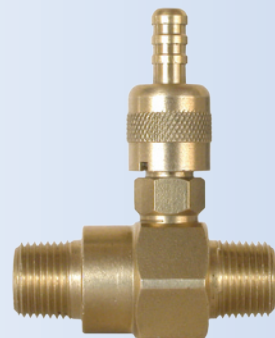

Part#	85.300.090	MNPT Inlet
Part#	85.300.091	FNPT Inlet
Max Pressure	200 PSI	
Max Temperature	145° F	
Max Flow	25 GPM	
Inlet	3/8"	
Outlet	3/8" MNPT	
Weight	0.3 lbs	



PACKAGING: Packaged

O-RINGS

POPPING

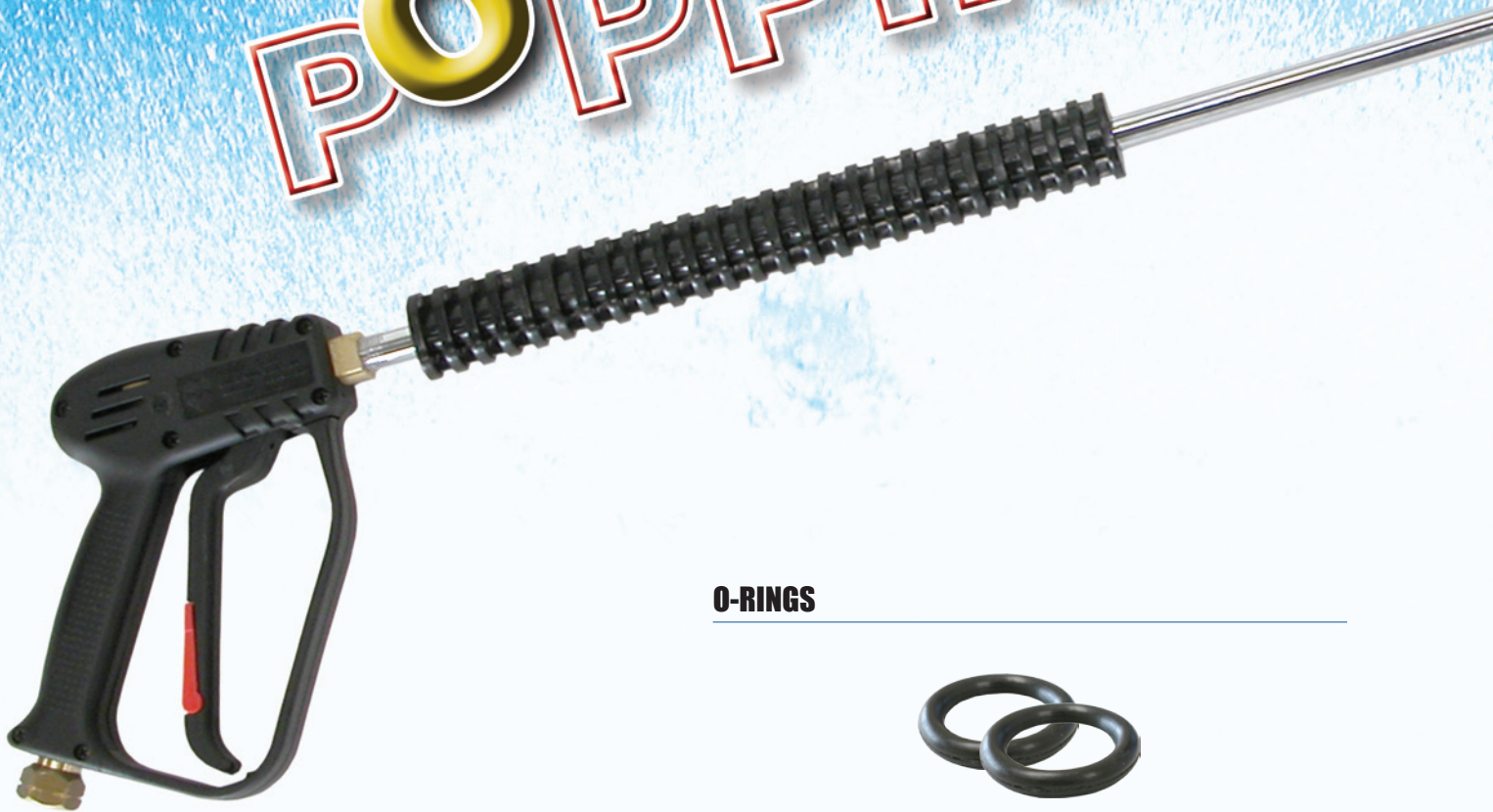

O-RINGS



Nozzle Coupler				
▼ Part#	Size	Type	Water	#/Pack
85.309.102	1/4"	EPDM	Cold	1
85.309.102V	1/4"	Viton	Hot	1
85.309.102C	1/4"	EPDM	Cold	100
85.309.102VC	1/4"	Viton	Hot	100
Hose Coupler				
▼ Part#	Size	Type	Water	#/Pack
85.309.103	3/8"	EPDM	Cold	1
85.309.103V	3/8"	Viton	Hot	1
85.309.103C	3/8"	EPDM	Cold	100
85.309.103VC	3/8"	Viton	Hot	100



PACKAGING: Packaged

OUT?



NOT ANYMORE! *New*

The new 'SURE-LOCK' locks O-rings into place.

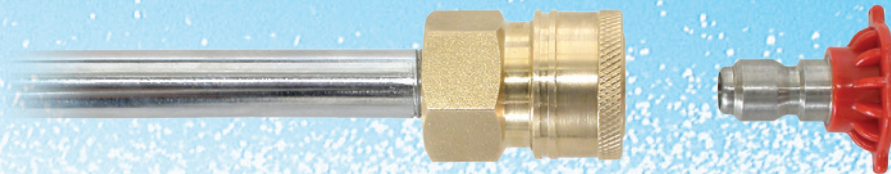

SURE-LOCK COUPLERS, QUICK CONNECT FNPT



▼ Part#	Material	Size	Weight
85.300.183	Brass	1/8"	0.15 lbs
85.300.102	Brass	1/4"	0.15 lbs
85.300.103	Brass	3/8"	0.20 lbs
85.300.153	Brass	1/2"	0.20 lbs

SURE-LOCK COUPLERS, QUICK CONNECT MNPT

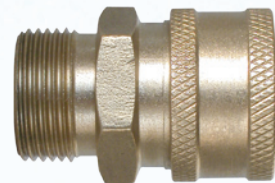

▼ Part#	Material	Size	Weight
85.300.187	Brass	1/8"	0.15 lbs
85.300.107	Brass	1/4"	0.15 lbs
85.300.108	Brass	3/8"	0.20 lbs
85.300.152	Brass	1/2"	0.20 lbs

COUPLERS, QUICK CONNECT FNPT

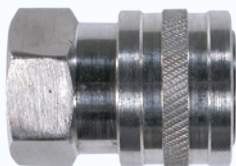

▼ Part#	Material	Size	Weight
85.300.102S	Stainless Steel	1/4"	0.15 lbs
85.300.114	Brass/Stainless Steel Sleeve	1/4"	0.15 lbs
85.300.103S	Stainless Steel	3/8"	0.20 lbs
85.300.115	Brass/Stainless Steel Sleeve	3/8"	0.20 lbs
85.300.153S	Stainless Steel	1/2"	0.20 lbs

COUPLERS, QUICK CONNECT MNPT



▼ Part#	Material	Size	Weight
85.300.107S	Stainless Steel	1/4"	0.15 lbs
85.300.116	Brass/Stainless Steel Sleeve	1/4"	0.15 lbs
85.300.108S	Stainless Steel	3/8"	0.20 lbs
85.300.117	Brass/Stainless Steel Sleeve	3/8"	0.20 lbs
85.300.152S	Stainless Steel	1/2"	0.20 lbs



PACKAGING: Packaged

COUPLER, 3 'O-RING' SEAL, STAINLESS STEEL

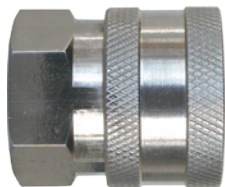

Part#	85.300.155S
Material	Stainless Steel
Thread	1/2" QC x 3/8" FNPT
Seal	3 'O-Rings'
Max Pressure	5,000 PSI
Weight	0.35 lbs

PLUGS, STAINLESS STEEL

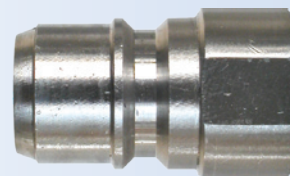

Part#	85.300.154S
Material	Stainless Steel
Thread	1/2" QD x 3/8" FNPT
Max Pressure	5,000 PSI
Weight	0.12 lbs

PLUGS, FNPT

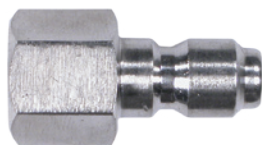

▼ Part#	Material	Size	Weight
85.300.181H	Hardened Steel	1/8"	0.20 lbs
85.300.101S	Stainless Steel	1/4"	0.05 lbs
85.300.101H	Hardened Steel	1/4"	0.05 lbs
85.300.101	Plated Steel	1/4"	0.05 lbs
85.300.104S	Stainless Steel	3/8"	0.10 lbs
85.300.104H	Hardened Steel	3/8"	0.10 lbs
85.300.104	Plated Steel	3/8"	0.10 lbs
85.300.151	Plated Steel	1/2"	0.15 lbs
85.300.151S	Stainless Steel	1/2"	0.15 lbs

PLUGS, MNPT



▼ Part#	Material	Size	Weight
85.300.185H	Hardened Steel	1/8"	0.35 lbs
85.300.109S	Stainless Steel	1/4"	0.05 lbs
85.300.109H	Hardened Steel	1/4"	0.05 lbs
85.300.109	Plated Steel	1/4"	0.05 lbs
85.300.105S	Stainless Steel	3/8"	0.10 lbs
85.300.105H	Hardened Steel	3/8"	0.10 lbs
85.300.105	Plated Steel	3/8"	0.10 lbs
85.300.150	Plated Steel	1/2"	0.15 lbs
85.300.150S	Stainless Steel	1/2"	0.15 lbs

PLUG, ALUMINUM WAND SAVER

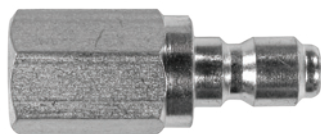

Part#	85.300.161
Material	Stainless Steel
Size	1/4" FNPT
Weight	0.1 lbs

COUPLER, ALUMINUM WAND SAVER

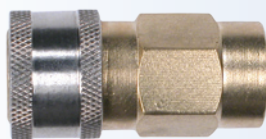

Part#	85.300.162
Material	Brass/Stainless Steel Sleeve
Size	1/4" FNPT
Weight	0.1 lbs

SWIVEL, STAINLESS STEEL

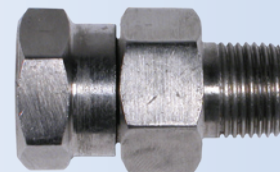

Part#	85.300.112	3/8"
Part#	85.300.113	1/4"
Pressure	4,000 PSI	
Temperature	200° F	
Weight	0.22 lbs	



PACKAGING: Packaged

SWIVEL, BRASS

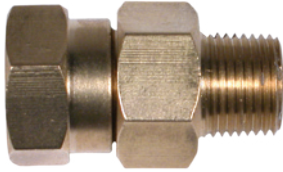

Part#	85.300.110	3/8"
Part#	85.300.111	1/4"
Pressure	3,000 PSI	
Temperature	200° F	
Weight	0.22 lbs	

SCREW-TYPE, MNPT

Fits Karcher.

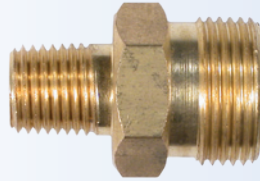

Part#	85.300.133	3/8"
Part#	85.300.132	1/4"
Inlet	MNPT	
Thread	M22 x 1½	
Weight	0.1 lbs	

SCREW-TYPE, FNPT

Fits Karcher.

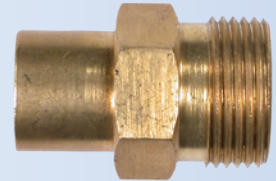

Part#	85.300.127	3/8"
Part#	85.300.126	1/4"
Inlet	FNPT	
Thread	M22 x 1½	
Weight	0.1 lbs	

SCREW-TYPE, Q CONNECT MNPT

Insulated Knob, Fits Karcher.



Part#	85.300.136	3/8"
Part#	85.300.135	1/4"
Inlet	MNPT	
Thread	M22 x 1½	
Weight	0.18 lbs	

SCREW-TYPE, Q CONNECT FNPT

Insulated Knob, Fits Karcher.

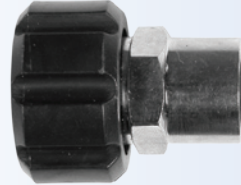

Part#	85.300.125	3/8"
Part#	85.300.124	1/4"
Inlet	FNPT	
Thread	M22 x 1½	
Weight	0.18 lbs	

M22 PLUG, STEEL

Insulated Knob.

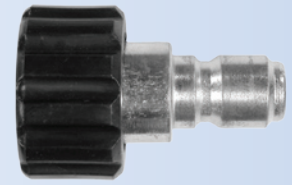

Part#	85.300.142	
Size	M22 x 3/8" quick connect	
Material	Steel	
Weight	0.2 lbs	

M22 X M22, FNPT

Insulated Knob.



Part#	85.300.146	
Size	M22F x M22F	
Weight	0.1 lbs	

PLUG, GARDEN HOSE MNPT



Part#	85.300.137	
Size	3/4" MGHT x 1/2" Plug	
Weight	0.1 lbs	

PLUG, GARDEN HOSE FEMALE

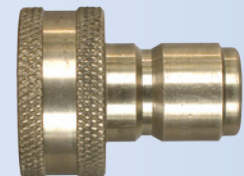

Part#	85.300.147	
Size	3/4" FGHT x 1/2" Plug	
Weight	0.1 lbs	



PACKAGING: Packaged

COUPLER, GARDEN HOSE FEMALE

Part#	85.300.138
Size	3/4" FGHT x 1/2" Coupler
Material	Brass
Weight	0.14 lbs

ADAPTER, GARDEN HOSE HEX

Full Assembly.



Part#	85.300.119	3/8" MNPT
Part#	85.300.120	1/2" MNPT
Inlet	3/4" FGHT	
Spring/Filter	Stainless Mesh #60	
Material	Brass	
Weight	0.4 lbs	

ADAPTER, GARDEN HOSE HEX

Full Assembly.

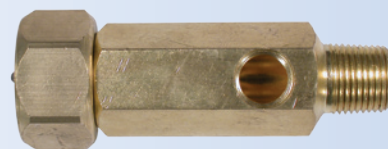

Part#	85.300.128	3/8" MNPT
Part#	85.300.131	1/2" MNPT
Inlet	3/4" FGHT	
Port	1/4" FNPT	
Spring/Filter	Stainless Mesh #60	
Material	Brass	
Weight	0.44 lbs	

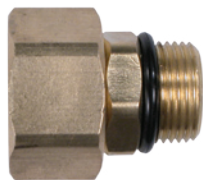
M22, GARDEN HOSE

Part#	85.300.141
Size	3/4"
Material	Brass
Weight	0.16 lbs

SWIVEL, NOZZLE BODY FEMALE

Single.

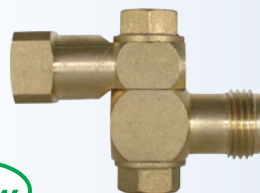

Part#	90.900.003
Size	1/4"
Material	Brass

SWIVEL, NOZZLE BODY MALE

Single.

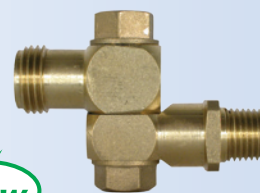

Part#	90.900.049
Size	1/4"
Material	Brass

SWIVEL, NOZZLE BODY FEMALE

Double.

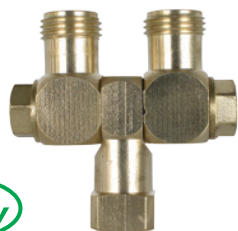

Part#	90.900.004
Size	1/4"
Material	Brass

SWIVEL, NOZZLE BODY MALE

Double.

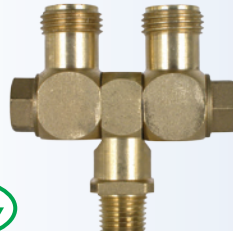

Part#	90.900.050
Size	1/4"
Material	Brass

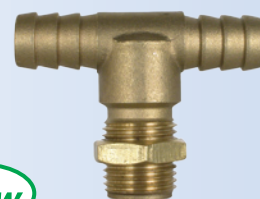
TEE, NOZZLE BODY

Part#	90.900.053	1/2"
Part#	90.902.038	3/8"
Size	1/2" Barb	
Material	Brass	



PACKAGING: Packaged

ELBOW, NOZZLE BODY



Part#	90.900.052	1/2"
Part#	90.901.038	3/8"
Size	90° Elbow	
Material	Brass	

80° FAN NOZZLE



Part#	Material
90.000.802	Brass
90.000.803	Brass
90.000.804	Brass
90.000.805	Brass
90.000.808	Brass
90.000.810	Brass

80° FAN NOZZLE



Part#	Material
90.304.802	304 Stainless Steel
90.304.803	304 Stainless Steel
90.304.804	304 Stainless Steel
90.304.805	304 Stainless Steel
90.304.808	304 Stainless Steel
90.304.810	304 Stainless Steel

NOZZLE, ORIFICE

410 Hardened Stainless Steel



Part#	Orifice
90.410.001	#1
90.410.002	#2
90.410.003	#3
90.410.004	#4
90.410.005	#5
90.410.006	#6
90.410.008	#8

BODY CAP, NOZZLE

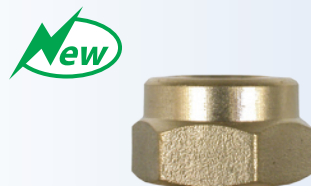

Part#	90.900.002
Depth	Shallow
Material	Brass

BODY CAP, NOZZLE



Part#	90.900.006
Depth	Deep
Material	Brass

PLATE, BLOCKOFF



Part#	90.900.016
Material	Brass

SCREENS, BRASS



Part#	90.900.009
Material	Brass

SCREENS, PLASTIC



Part#	Mesh
90.900.011	#50
90.900.111	#50 with check ball
90.900.012	#100
90.900.112	#100 with check ball



SECTION 7

KITS AND CUSTOM ACCESSORIES

KITS AND CUSTOM ACCESSORIES

Hose Reels	104
Engine Parts	105
Sandblast Kits	106
Brushes and Kits	107
Power Accessories	108
Fluid Accessories	109
Pressure Gauges	110
Chemical Kits and Parts	111
Filters and Strainers	112
Miscellaneous Water Accessories	113
Electrical Accessories	114
Replacement Blocks and Feet	115
Tires and Wheels	116
Tiller Tines and Blades	117

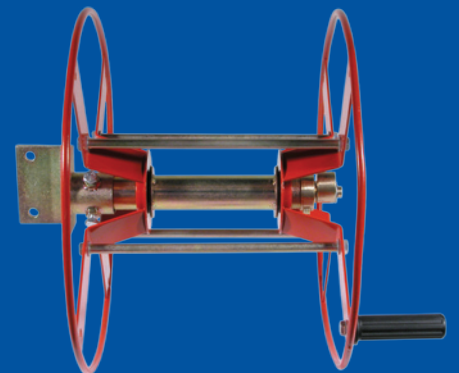



PACKAGING: Packaged

HOSE REEL, 400 & 200 FT.

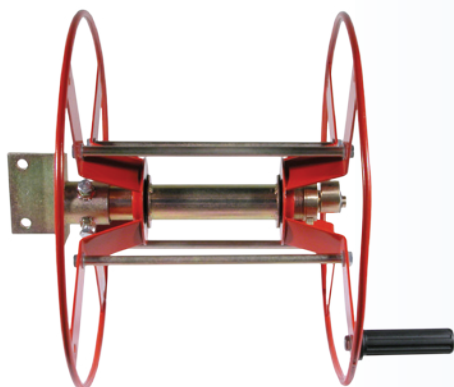

Part#	85.401.040	85.401.020
Max Pressure	3,000 PSI	3,000 PSI
Max Temperature	160° F	160° F
Hose Size	1/2"	1/2"
Hose Capacity	400 ft.	200 ft.
Dimensions	19.5"x13"x19.5"	19.5"x13"x9.5"
Weight	21.7 lbs	21.7 lbs

HOSE REEL, 200 & 100 FT.



Part#	85.402.002	85.402.001
Max Pressure	3,000 PSI	3,000 PSI
Max Temperature	160° F	160° F
Hose Size	3/8"	3/8"
Hose Capacity	200 ft.	100 ft.
Dimensions	20"x15.75"x17.25"	17"x18"x13.5"
Weight	18 lbs	16 lbs

HOSE REEL, 75 & 50 FT.



Part#	85.402.000	85.402.050
Max Pressure	3,000 PSI	3,000 PSI
Max Temperature	160° F	160° F
Hose Size	3/8"	3/8"
Hose Capacity	75 ft.	50 ft.
Dimensions	13"x18"x11"	13"x11.75"x11"
Weight	12 lbs	11 lbs



PACKAGING: Packaged

AIR FILTER, HONDA GC



Part#	17211-ZL8-003
Engine	Honda GC 160, 5HP
Weight	0.15 lbs

AIR FILTER, HONDA GX

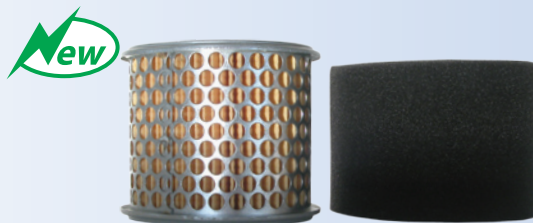

Part#	17211-ZE1-822
Engine	Honda GX 160, 5.5HP
Engine	Honda GX 200, 6.5HP
Weight	0.3 lbs

AIR FILTER, HONDA GX

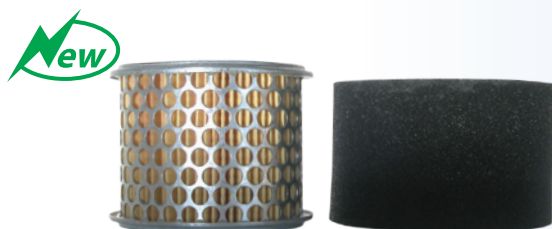

Part#	17211-ZE3-505
Engine	Honda GX 340, 11HP
Engine	Honda GX 390, 13HP
Weight	0.3 lbs

AIR FILTER, HONDA GX

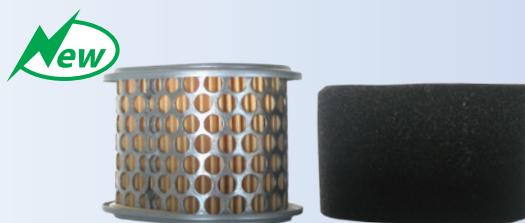

Part#	17210-ZE2-505
Engine	Honda GX 240, 8 HP
Engine	Honda GX 270, 9 HP
Weight	0.3 lbs

SPARK PLUGS, NGK (RESISTOR STYLE)



Part#	Plug#	Engine
85.519.001	BPR6ES	GC and GX, 4-13HP

GAS CAP

Replacement cap for all Honda GX engines.

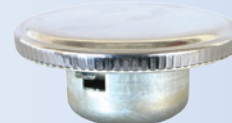

Part#	17620-ZE2-W00
Weight	0.18 lbs

OIL DIPSTICK



Part#	For Models
15600-735-003	9-11 HP Honda (GX260-GX390)
15600-ZE1-003	4-6.5 HP Honda (GC135-GX200)



PACKAGING: Packaged

SANDBLASTER, HEAVY DUTY WET

Please note, 0° Meg nozzle (85.200.____) is not included.

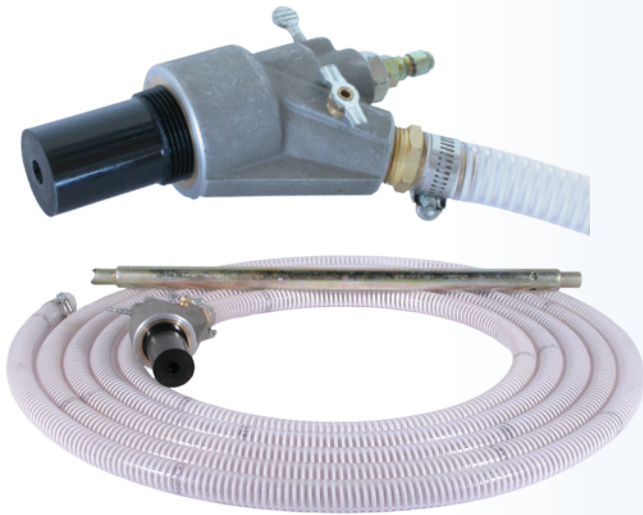

Part#	9001-9
Max Pressure	5,500 PSI
Max Flow	10 GPM
Min Flow	3 GPM
Weight	9.25 lbs

COMPONENTS	Part#
Nozzle	10TCSSSBE
Probe	9050-9
Head	9051-9C
3/4" Hose (25' required)	G941K-075
Hose Clamp	HS-8
1/4" Plug	85.300.107

SANDBLASTER, KIT



Part#	85.400.002
Max Pressure	3,500 PSI
Max Flow	10 GPM
Weight	9.25 lbs

COMPONENTS	Part#
Head	85.400.009
1/2" Hose (20' required)	85.202.071
Tube	85.400.010
Male Plug	85.300.101
Nozzle	124700000

AVAILABLE SEPERATELY	Part#
Nozzle (1.2 diameter)	124720310
Nozzle (1.4 diameter)	124720320



PACKAGING: Packaged

NYLON BRUSH



Part#	85.400.011
Max Pressure	3,000 PSI
Max Temperature	140° F
Inlet	1/4" MNPT
Weight	1.6 lbs

NYLON BRUSH, ROTATING

Provides low pressure scrubbing action.



Part#	85.400.008
Max Pressure	2,000 PSI
Max Temperature	140° F
Inlet	1/4" QC plug or Male M22
Weight	1.15 lbs

NYLON BRUSH, FIXED



Part#	85.400.040
Max Pressure	3,000 PSI
Max Temperature	140° F
Inlet	Male M22
Weight	0.4 lbs



PACKAGING: Packaged

THROTTLE CONTROL KIT

Throttles down your engine in a no-load by-pass to prolong the engine and pumps life, also reduces fuel consumption.

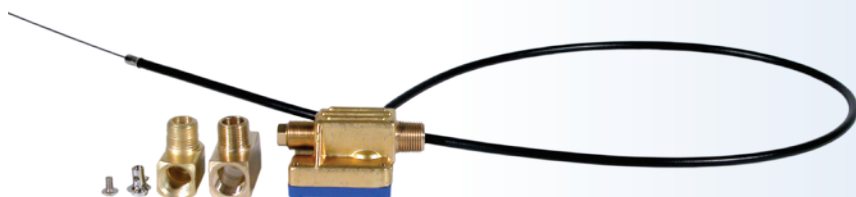

Part#	85.400.114
Max Pressure	4,000 PSI
Max Temperature	145° F
Cable Length	42"
Inlet	3/8" MNPT
Actuation Pressure	1,000 PSI
Weight	1.15 lbs

BATTERY, PRESSURE WASHER

Call us for information on shipping regulations.



Part#	85.603.002
Voltage	12V
Col Cranking Amps	240A
Ampere Hours	19A
Terminal	LUG
Dimensions	7" x 4" x 6"
Weight	10 lbs

TAPE, TEFLON



Part#	85.400.110
Size	W1/2" x L480"
Number per Box	12
Weight	0.4 lbs

SOAP HOLDER

Affixes to the frame to conveniently hold a 1 gallon soap container in place.



Sample.



Part#	85.601.010
Weight	1.15 lbs



PACKAGING: Packed

SOAP DETERGENT

All detergents sold in boxes of 4

CAR WASH



Part#	85.490.050
Volume	3.78L/1Gallon
Weight	9 lbs

HOUSE & SIDING



Part#	85.490.051
Volume	3.78L/1Gallon
Weight	9 lbs

DECK & FENCE



Part#	85.490.052
Volume	3.78L/1Gallon
Weight	9 lbs

HEAVY DUTY



Part#	85.490.053
Volume	3.78L/1Gallon
Weight	9 lbs

SOAP DETERGENT, MULTI-PACK

Contains 1 of each detergent type shown above.



Part#	85.490.054
Volume	3.78L/1Gallon
Weight	9 lbs

SOAP DETERGENT, 5 GALLON JUGS

Sold Individually.



Part#	Type	Volume	Weight
85.490.055	Car Wash	18.92L/5Gallon	45 lbs
85.490.056	House & Siding	18.92L/5Gallon	45 lbs
85.490.057	Deck & Fence	18.92L/5Gallon	45 lbs
85.490.058	Heavy Duty	18.92L/5Gallon	45 lbs

PUMP ANTI-FREEZE SOLUTION

Protect your pump from freezing over the winter. Attaches to any pump inlet to fill pump chamber with anti-freeze solution.



Twist on and depress button.



Part#	Description	Volume
85.490.042	"BE" Label	6 oz.
85.490.041	Generic Label	6 oz.

PUMP OIL

Ideal for high pressure pumps. Non detergent and non foaming. Specially formulated and rated for superior rust protection and oxidation protection. Not for use in engine.

Note: Change oil after the first 50 hours of operation, then every 3 months or as needed. Fill oil half-way on the indicator site glass only. Do not over-fill.

Fill oil half-way.



Part#	Volume	Weight
85.490.000	1 Litre	1 lbs



PACKAGING: Packaged

2.5" PRESSURE GAUGE, GLYCERIN, STAINLESS STEEL

Install on outlet of pump to measure system performance.



▼ Part#	Max PSI	Inlet	Size	Weight
85.300.100	100 PSI	1/4" MNPT	2.5"	0.45 lbs
85.300.200	200 PSI	1/4" MNPT	2.5"	0.45 lbs
85.300.300	300 PSI	1/4" MNPT	2.5"	0.45 lbs
85.300.600	600 PSI	1/4" MNPT	2.5"	0.45 lbs
85.301.000	1,000 PSI	1/4" MNPT	2.5"	0.45 lbs
85.302.000	2,000 PSI	1/4" MNPT	2.5"	0.45 lbs
85.303.000	3,000 PSI	1/4" MNPT	2.5"	0.45 lbs
85.305.000	5,000 PSI	1/4" MNPT	2.5"	0.45 lbs

4" PRESSURE GAUGE, GLYCERIN, STAINLESS STEEL

Install on outlet of pump to measure system performance.



Part#	84.000.100
Max Pressure	100 PSI
Size	4"
Inlet	1/4" MNPT
Weight	1.05 lbs

2.5" PRESSURE GAUGE KIT, QUICK-CONNECT

Easy quick connect setup installs on outlet of pump to measure system performance.



Part#	85.305.001
Max Pressure	5,000 PSI
Size	2.5"
Inlet	3/8" quick connect plug
Outlet	3/8" quick connect coupler
Weight	0.8 lbs

COMPONENTS	Part#
5,000 PSI Gauge	85.305.000
Q/D Stainless Steel Sleeve	85.300.106



PACKAGING: Packaged

CHEMICAL HOSE ASSEMBLY

Includes hose and suction filter. Available in 3, 4, and 6 foot lengths.



▼ Part#	Length	Weight
85.400.005	3 ft.	0.1 lbs
85.400.013	4 ft.	0.1 lbs
85.400.006	6 ft.	0.1 lbs

CHEMICAL KIT, HIGH PRESSURE

Placed on the inlet side of pump. Used to provide soap discharge at pressure washer's Maximum Pressure.



Part#	85.400.003
Max Pressure	3,500 PSI
Max Temperature	180° F
Max Flow	8 GPM
Weight	1.05 lbs

COMPONENTS	Part#
Soaper Body Assembly	7655
GHF x 3/8" MNPT	85.300.119
GHM x 1/2" FNPT	85.300.130
Soaper Hose Assembly	85.400.005
Brass Adapter 1/2" x 3/8" MNPT	85.706.086

FILTERS, CHEMICAL SUCTION

Filters out abrasives found in chemicals and cleaning agents. Check valve prevents back flow.



▼ Part#	Outlet	Check Valve	Weight
85.300.050	1/4" hose barb	No	0.01 lbs
85.300.052	1/4" hose barb	No	0.01 lbs

CHEMICAL KIT, LOW PRESSURE

Placed on the outlet side. Unique siphoning design draws chemicals or soap to aid in your cleaning flexibility. Be sure to use the black low pressure nozzle and open the adjusting knob on the injector when in use.



Part#	85.400.001
Flow	3 - 5 GPM
Weight	1.05 lbs

COMPONENTS	Part#
Soap Hose Assembly	85.400.005
Soaper Body Assembly	85.300.092
↳ Body Kit Quick Connect	85.300.096
↳ Injector Barb Assembly	0203100020



PACKAGING: Packaged

FILTER, WATER INLET

Protects the pump from contaminants in the water. Cap easily unscrews with a spanner wrench to change filter.



Part#	85.300.059
Weight	2.85 lbs

REPLACEMENTS	Part#
Filter Cartridge	SP5-25

STRAINER, INLET

Protects the system from contaminants in the water.



Part#	95.000.003	1/2"
Part#	95.000.004	3/4"
Max Pressure	175 PSI	
Max Flow	16 GPM	
Inlet/Outlet	FNPT	
Screen	#50	
Weight	0.3 lbs	

FILTER, WATER INLET

Protects the pump from contaminants in the water. Cap easily unscrews with an Allen Key to clean out screen.



Part#	85.300.058
Max Pressure	170 PSI
Max Temperature	180° F
Max Flow	10 GPM
Inlet	3/4" FGHT
Outlet	1/2" MNPT
Ports	Dual 1/4" FNPT with Plugs
Weight	0.55 lbs

COMPONENTS	Part#
1" Stainless Steel Screen #50	85.309.050
Housing with 1/4" Male Plugs	85.309.046
Plastic Blue Cap	85.309.051
Garden Hose Adapter Kit	85.300.120

FILTER, INLINE HIGH PRESSURE

Protects the system from contaminants in the water.

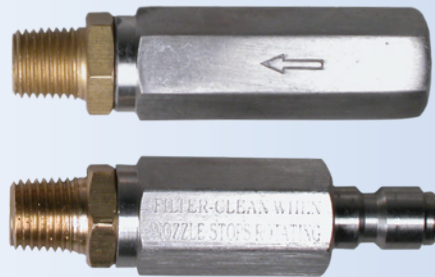

Part#	85.211.007	Quick Connect
Part#	85.211.006	FNPT
Max Pressure	5,500 PSI	
Max Temperature	200° F	
Max Flow	8 GPM	
Inlet	1/4" MNPT	
Outlet	1/4"	
Weight	0.23 lbs	



PACKAGING: Packaged

FILTER, WATER INLET



Part#	85.300.054
Max Pressure	160 PSI
Max Temperature	175° F
Max Flow	8 GPM
Inlet	3/4" FGHT
Outlet	1/2" MNPT
Weight	0.5 lbs

TAP, WITH FLOAT

Protects pump by maintaining a constant flow by monitoring water level in a reservoir. Economical and low maintenance.



Part#	85.300.070
Max Pressure	145 PSI
Max Temperature	140° F
Inlet	3/4" plug
Material	Brass
Weight	0.55 lbs

VALVE, GARDEN HOSE SHUTOFF



Part#	GHV-2
Max Pressure	60 PSI
Material	Plastic
Weight	0.1 lbs

WASHER, FILTER



Part#	85.308.120
Dimensions	1" OD
Screen	#60
Weight	0.005 lbs

WASHER, GARDEN HOSE



Part#	85.308.121
Dimensions	1" OD
Weight	0.005 lbs

GUTTER CLEANER

Turns wands into efficient gutter cleaners so that gutters can be cleaned from the ground.



Part#	85.400.007
Max Pressure	3,000 PSI
Outlet	1/4" quick connect
Inlet	1/4" plug
Weight	0.55 lbs

GUTTER CLEANER KIT

This gutter pole attaches to the new style BE Long Wand. Held firmly in place by an M22 Fitting.



Part#	85.400.033
Max Pressure	3,000 PSI
Outlet	40°, #40 Spray Tip (1/4" FNPT)
Inlet	M22 Male
Weight	0.55 lbs



PACKAGING: Packaged

PRESSURE SWITCH, 3 WIRE

Mounts on the inlet side. Protects system by shutting off burner at a preset temperature. 3 wire allows for normally open or normally closed. Not rated for inductive loads. **Must be installed by an electrician to avoid electric shock.**

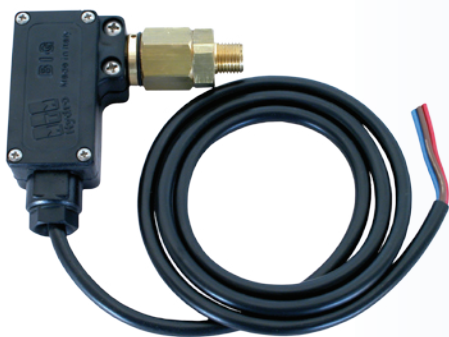

Part#	85.300.082
Max Pressure	4,100 PSI
Max Temperature	195° F
Activated Pressure	580 PSI
Inlet	1/4" FNPT
Voltage	250V
Amperes	15A
Weight	0.6 lbs

VACUUM SWITCH

Mount on inlet side. When water flows the burner starts. When flow ceases it shuts off burner.



Part#	85.300.080
Size	3.5"
Voltage	250V
Amperes	16A
Max Temperature	140° F
Weight	1.25 lbs

THERMOSTAT, WITH IMMERSED PROBE

Provides accurate temperature control to shut down burner and protect system.

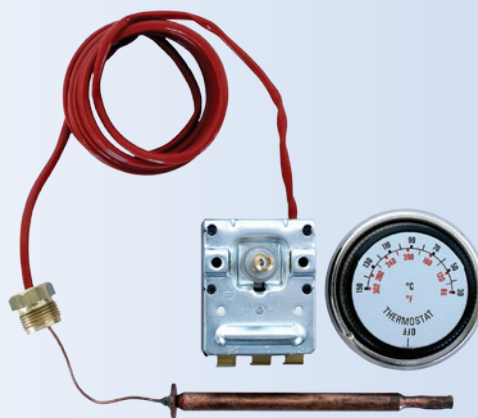

Part#	85.400.070
Max Pressure	4,000 PSI
Max Temperature	300° F
Coil Length	59"
Probe	4 1/4"
Amperes	15A
Weight	0.3 lbs

TACHOMETER



Part#	806-109
Weight	0.1 lbs



PACKAGING: Packaged

MOUNTING BLOCK



Part#	85.603.018	Brass
Part#	85.603.016	Aluminum
Inlet/Outlet	3/8" MNPT	
Weight	1.66 lbs	

RUBBER FOOT, MOULDED

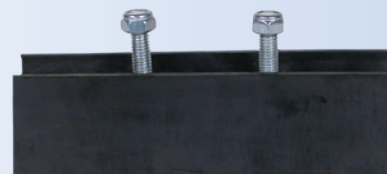

Part#	85.660.005
Bolt Dimensions	M8 x 55
Weight	0.85 lbs

RUBBER FOOT



Part#	85.660.007
Bolt Dimensions	M8 x 45
Weight	0.3 lbs

RUBBER GROMMET

Mounts on frame to hold nozzles.



Part#	85.660.008
-------	------------



PACKAGING: Packaged

TIRES, TUBED PNEUMATIC WHEEL ASSEMBLY, 13"



Part#	85.660.006	Nylon Bushing
Part#	85.660.006B	Ball Bearing
Tire Pressure	40 PSI Max.	
Size	13.0 x 5.00 - 6.00	
Type	2 ply ratng	
Bearing	0.75" x 2.25"	
Weight	5.6 lbs	

TIRES, TUBED PNEUMATIC WHEEL ASSEMBLY, 10"



Part#	85.660.004	Nylon Bushing
Part#	85.660.004B	Ball Bearing
Tire Pressure	30 PSI Max.	
Size	4.10 x 3.50 - 4.00	
Type	2 ply ratng	
Bearing	0.75" x 2.25"	
Weight	3.7 lbs	

TIRES, FOAM-FILLED 13"



Part#	85.660.018	
Material	Foam Filled, No Air	
Size	13.0 x 5.00 - 6.00	
Bearing	0.64" x 2.25" Nylon Bushing	
Weight	7.3 lbs	

TIRES, FOAM-FILLED 10"



Part#	85.660.017	
Material	Foam Filled, No Air	
Size	4.10 x 3.50 - 4.00	
Bearing	0.64" x 2.25" Nylon Bushing	
Weight	5.3 lbs	

WHEEL BARROW TIRES, 16"



Part#	51.450.016	51.484.008
Material	Foam Filled, No Air	Pneumatic 30 PSI Max.
Size	480/400 x 8	480/400 x 8
Ball Bearing	3/4"	3/4"
Weight	12 lbs.	12 lbs.

COMPOSITE TIRE, 8.25"



Part#	85.660.014	
Material	Solid Composite	
Size	8.25", Axle size 3/4"	
Weight	1.96 lbs	



PACKAGING: Packaged

TILLER TINE (LEFT), FITS HONDA 501 TILLER



Part#	63.370.190
Tiller Type	Honda F501
Length	9 5/8"
Side	Left Hand Tine
OEM Honda#	72461-733-750

TILLER TINE (RIGHT), FITS HONDA 501 TILLER



Part#	63.370.194
Tiller Type	Honda F501
Length	9 5/8"
Side	Right Hand Tine
OEM Honda#	72465-733-750

TILLER TINE (LEFT), FITS HONDA F220 TILLER



Part#	63.370.210
Tiller Type	Honda F220
Length	7 3/4"
Side	Left Hand Tine
OEM Honda#	72461-737-A00

TILLER TINE (RIGHT), FITS HONDA F220 TILLER



Part#	63.370.206
Tiller Type	Honda F220
Length	7 3/4"
Side	Right Hand Tine
OEM Honda#	72465-737-A00

AERATOR TINE



Part#	55.373.017
Fits	Ryan, Classen, Bluebird H530A Aerator

BLADE SET, OVERSEEDER



Part#	55.373.241
Fits	Ryan, Bluebird P18 Overseeder
Set	20 blades



BE Pressure Supply's warranty procedure and policy is as follows: **orders received with missing parts need to be reported within 48 hours. All warranty replacements require a BE Pressure Supply pre-approval before returning merchandise for warranty claim.** Warranty claims without this pre-approval will not receive credit and any freight claims or damages must be reported within 48 hours.

PROCEDURE

1. When a dealer encounters a warranty problem, call BE PRESSURE SUPPLY and ask for Customer Service. Please have your invoice # and/or unit serial # ready.
2. If a claim is going to be processed, a Return Goods Authorization (RGA) must be obtained before returning the product.
3. BE PRESSURE SUPPLY will confirm this Return Goods Authorization number with a faxed copy to the dealer.
4. This warranty part has to be returned within 30 days to BE PRESSURE SUPPLY together with the applicable BE invoice copies and a copy of the Pre-Approval. Without proof of purchase we are unable to proceed with Warranty.
5. Product being returned for warranty consideration is to be shipped prepaid freight. If warranty is approved, product will be returned prepaid freight. In the US, return via UPS Ground. In Canada, return via expedited mail. **DO NOT RETURN ANYTHING COLLECT OR IT WILL BE REFUSED.** Please write the Return Goods Authorization # on the outside of the package being shipped, along with including a copy of the RGA inside the package.
6. BE PRESSURE SUPPLY will review the warranty claim once the merchandise is received, and will advise the dealer either of a credit for the merchandise returned, or a rejection of the claim. If rejected, the product will be repaired, billed to the dealer's account, and then returned to dealer.

LIMITATION OF LIABILITY

Subject to government regulations, BE PRESSURE SUPPLY liability of any claim, of any kind, including negligence for any loss or damages arising out of, connected with, or resulting from the order, or from the performance or breach thereof, or from the manufacture, sale, delivery, resale, repair, or use of any goods or parts covered by or furnished under an order, shall in no case exceed the price applicable to the goods or parts thereof which gives rise to the claim. In no event shall BE PRESSURE SUPPLY be liable for special or consequential damages, including downtime or labour resulting from damage.

POLICY

The foregoing warranty is exclusive and in lieu of all other conditions or warranties, whether written, oral or implied (including any warranty of merchantability or fitness for purpose).

If it appears, within the specified warranty period, from the date of delivery by the Dealer to the ultimate Purchase, that the goods do not meet the warranty period, all such liability shall terminate.

This warranty does not cover depreciation or damage caused by normal wear, accident, improper maintenance, improper protection in storage, or improper use. The cost of normal maintenance and normal replacement of service items such as belts, lubricant or oils are the Customer's responsibility.

Warranty as set forth in the preceding paragraphs shall not apply to supplier equipment such as engines or electric motors, such being subject to the warranty of their own respective manufacturers. Take them to your nearest warranty depot.

The foregoing shall constitute the sole remedy of the Dealer and the sole liability of BE PRESSURE SUPPLY.

WARRANTY PERIODS

1. All pumps carry a 5 year warranty against manufacturer's defect, except for 2DX & 5DX Cat pumps, which carry a 2 year warranty. Note that this warranty only applies to defective manufacturer's workmanship as determined by the applicable manufacturer. This warranty does not apply where customer neglect, abuse, or "normal wear and tear" is involved. Items such as seal and valve kits are not warrantable. Pumps and gearboxes have a 12 month warranty against "normal use" when not commercially used. When commercially used, the warranty period is 90 days.

**** BE Pressure Supply does not pay for labor.**

2. Engine warranties are as per manufacturer's warranty policy in the engine owner operator's manual.

3. All other accessories and components, including Whirl-a-Ways and Long Wands, are warrantable for 90 days against manufacturer's defects. Whirl-A-Way heads are warrantable for 6 months. Rotary nozzles are warrantable for 'repair only' for 30 days from purchase.